

Product specification and dimensions

Condensate Drain

Series E-TRONIC

Type ED6100-LED

Electronic level sensed condensate drain
with alarm function

Maximum compressor capacity	100 m ³ /min.
Min./max. system pressure	0 bar / 16 bar
Valve type	2/2 way, direct acting
Valve orifice	4.0 mm
Valve seals	FPM
Inlet connection	1/2" (BSP or NPT)
Outlet connection	1/4" (BSP or NPT)
Inlet height	11 cm (top) and 1.5 & 7.5 cm (side)
Minimum medium temperature	1 °C
Maximum medium temperature	50 °C
Supply voltage options	230VAC / 115VAC 24VAC / 24VDC
Connectors	DIN 43650-B
Serviceable valve	Yes
TEST feature	Yes
Environmental protection Integrated mesh strainer	IP65 (NEMA4) Yes
Alarm contact options	Alarm Normally Closed (NC) Alarm Normally Open (NO)
LED-Display	Yes

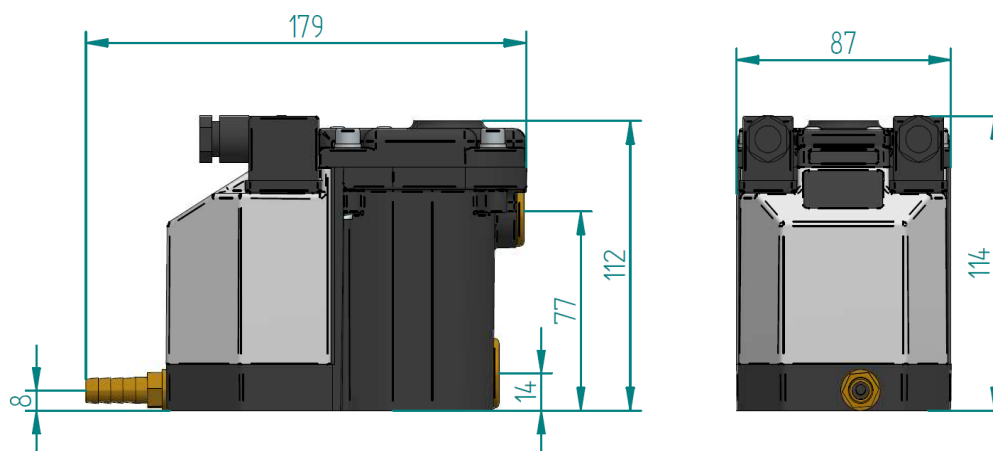

pure! GmbH
Im Dachsstück 15, D-65549 Limburg
Telefon: +49 6431/4961240
Telefax: +49 6431/4961241
E-Mail: support@pure-gmbh.com