

Product specification and dimensions

Condensate Drain Series E-TRONIC Type ED5000

Electronic level sensed condensate drain
with alarm function

Maximum compressor capacity Min./max. system pressure Valve type	10 m ³ /min. 0 bar/16 bar 2/2 way, direct acting
Valve orifice	2.0 mm
Valve seals	FPM
Inlet connection	1/2" (BSP or NPT)
Outlet connection	1/4" (BSP or NPT)
Inlet height	7.4 cm
Minimum medium temperature	1° C
Maximum medium temperature	50° C
Supply voltage options	230VAC / 115VAC 24VAC / 24VDC DIN 43650-B
Connector	
Serviceable valve	Yes
TEST feature	Yes
Environmental protection	IP65 (NEMA4)
Integrated mesh strainer	Yes
Alarm	Yes, LED indication only.

*For external alarm options please see the ED6000 range.

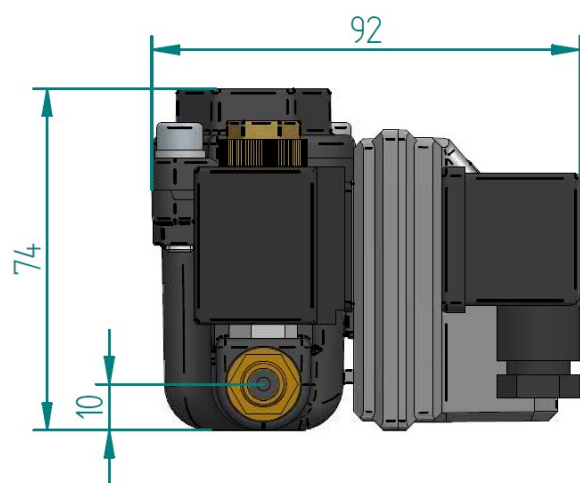
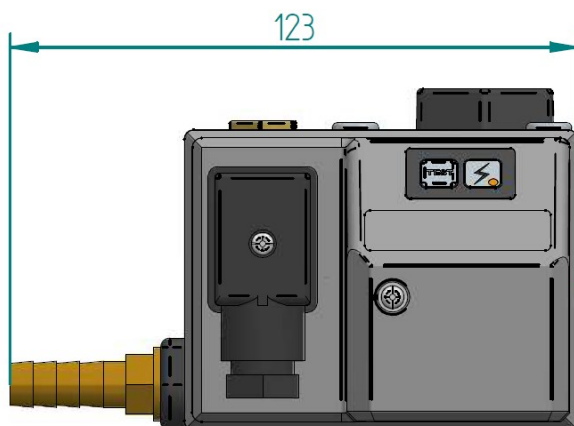

pure! GmbH
Im Dachsstück 15, D-65549 Limburg
Telefon: +49 6431/4961240
Telefax: +49 6431/4961241
E-Mail: support@pure-gmbh.com