

Product specification and dimensions

Compressed air system optimization

Series AIR SAVER

Type PURE-PRO230-G2

Motorized ball valve for air savings in piping systems

Min./max. System pressure	0 - 16 bar
Voltage options	115VAC or 230VAC 50/60Hz. (Please specify)
Opening and closing time	105 Seconds / 90°
Medium Temperature	1 - 100 °C
Ambient temperature	1 - 50 °C
Illuminated LCD Display	Display shows date, time, valve status, batterie runtime
Program setting	Seven-day program setting (up to 16 times a day)
Inlet Connection	2" (BSP oder NPT)
Ball housing Valve	Nickel-plated brass
maintenance possible	yes
Manual valve seal	yes
Remote controllable	yes
Degree of protection	IP54 (NEMA13)

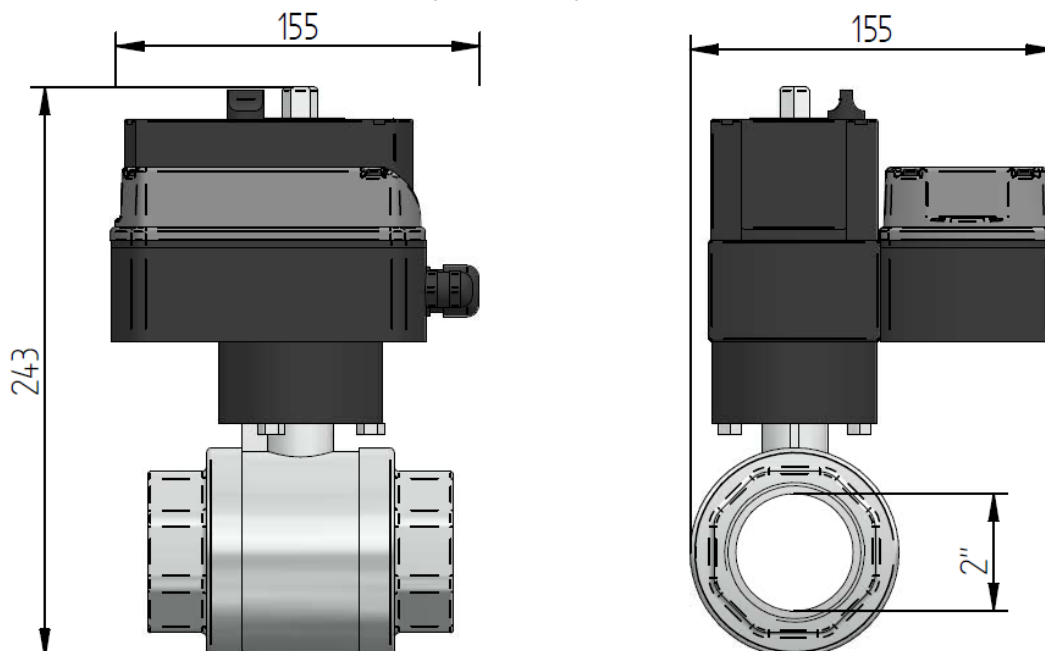

pure! GmbH
Im Dachsstück 15, D-65549 Limburg
Telefon: +49 6431/4961240
Telefax: +49 6431/4961241
E-Mail: support@pure-gmbh.com