

**Adsorption dryer**

**K-MT 10-95**

Dokument-ID: DMN-K-MT10-95/R02



**Operating instructions**

CE 0525

# Declaration of Conformity

**Parker Hannifin Manufacturing Germany GmbH & Co. KG**  
**Gas Separation and Filtration Division EMEA**

**Im Teelbruch 118**

**D – 45219 Essen Kettwig**

hereby declares with sole responsibility, that the products

**compressed air adsorption dryer**

**K-MT 10–95**

**assembly type: assembly acc. to Art. 4 No. 2b,**

which this declaration refers to, conform to Directive **2014/68/EU** and were subjected to a conformity assessment according to Annex III Modules B + D (for assembly assessment).

The quality assurance system is monitored by the service provider stated below

*Lloyd's Register Quality Assurance GmbH (identification number 0525)*

*Am Sandtorkai 41, D - 20457 Hamburg.*

The assembly consists of pressure appliances according to the classification list (attached to the technical documentation provided by the manufacturer).

| Pressure vessel |          |                         |            |                |        |
|-----------------|----------|-------------------------|------------|----------------|--------|
| Dryer           | Quantity | Allowable pressure (PS) | Volume [l] | Category (PED) | Module |
| K-MT 10         | 2        | 16                      | 20         | II             | B + D  |
| K-MT 15         | 2        | 16                      | 24         | II             | B + D  |
| K-MT 20         | 2        | 16                      | 36         | II             | B + D  |
| K-MT 25         | 2        | 16                      | 45         | II             | B + D  |
| K-MT 35         | 2        | 16                      | 55         | II             | B + D  |
| K-MT 45         | 2        | 16                      | 70         | III            | B + D  |
| K-MT 60         | 2        | 16                      | 105        | III            | B + D  |
| K-MT 75         | 2        | 16                      | 132        | III            | B + D  |
| K-MT 95         | 2        | 16                      | 175        | III            | B + D  |

| Piping  |                         |                 |                |         |
|---------|-------------------------|-----------------|----------------|---------|
| Dryer   | Allowable pressure (PS) | Dimensions (DN) | Category (PED) | Module  |
| K-MT 10 | 16                      | DN25            | Art.4.3        | Art.4.3 |
| K-MT 15 | 16                      | DN25            | Art.4.3        | Art.4.3 |
| K-MT 20 | 16                      | DN25            | Art.4.3        | Art.4.3 |
| K-MT 25 | 16                      | DN40            | Art.4.3        | Art.4.3 |
| K-MT 35 | 16                      | DN40            | Art.4.3        | Art.4.3 |
| K-MT 45 | 16                      | DN40            | Art.4.3        | Art.4.3 |
| K-MT 60 | 16                      | DN50            | Art.4.3        | Art.4.3 |
| K-MT 75 | 16                      | DN50            | Art.4.3        | Art.4.3 |
| K-MT 95 | 16                      | DN65            | I              | A       |

| Filter  |        |          |                         |            |                |         |
|---------|--------|----------|-------------------------|------------|----------------|---------|
| Dryer   | Filter | Quantity | Allowable pressure (PS) | Volume [l] | Category (PED) | Module  |
| K-MT 10 | GL 9   | 2        | 16                      | 1,1        | Art.4.3        | Art.4.3 |
| K-MT 15 | GL 9   | 2        | 16                      | 1,1        | Art.4.3        | Art.4.3 |
| K-MT 20 | GL 9   | 2        | 16                      | 2          | Art.4.3        | Art.4.3 |
| K-MT 25 | GL 11  | 2        | 16                      | 2          | Art.4.3        | Art.4.3 |
| K-MT 35 | GL 11  | 2        | 16                      | 2          | Art.4.3        | Art.4.3 |
| K-MT 45 | GL 12  | 2        | 16                      | 6          | I              | B+D     |
| K-MT 60 | GL 13  | 2        | 16                      | 6          | I              | B+D     |
| K-MT 75 | GL 13  | 2        | 16                      | 6          | I              | B+D     |
| K-MT 95 | GL 14  | 2        | 16                      | 6          | I              | B+D     |

The following standards / technical specifications were used:

- harmonized standards: DIN EN ISO 12100:2011-03, DIN EN 61000-6-2, DIN EN 60204

The following other EC directives were used

- 2014/30/EU
- 2014/35/EU

Essen,

19.07.2016

Datum / Date

**i. V. Dr. Jürgen Timmler**

Leiter Technik und Entwicklung /  
Manager Engineering and Development

# Machine passport

| Type designation    | K-MT ____ |
|---------------------|-----------|
| Order no.           |           |
| Order ID.           |           |
| Build no.           |           |
| Vessel no.          |           |
| Vessel no.          |           |
| Year of manufacture |           |

It is the responsibility of the owner,

- to enter for the first time any appliance data not stated above,
- to keep these appliance data up to date.

The above-stated appliance data provide for a clear identification of the dryer and its components, and significantly facilitate any service measures.

Further important data on the dryer such as the details on the permissible operating pressure and the electrical connection are found on the type plate (for position of the type plate see page 10).

# Table of contents

|   |           |
|---|-----------|
| <b>General information.....</b>                               | <b>7</b>  |
| Manufacturer's details .....                                  | 7         |
| Details on the dryer.....                                     | 7         |
| About these operating instructions .....                      | 8         |
| <b>For your own safety.....</b>                               | <b>9</b>  |
| General safety notes.....                                     | 9         |
| Signs, instruction plates and danger zones at the dryer ..... | 10        |
| Intended use of the dryer .....                               | 12        |
| <b>Transportation, installation and storage.....</b>          | <b>13</b> |
| Information on transportation packaging .....                 | 13        |
| What to do in the case of transport damage occurring? .....   | 13        |
| Transporting and installing the dryer .....                   | 14        |
| Storing the dryer .....                                       | 16        |
| <b>Technical product description .....</b>                    | <b>17</b> |
| Summary Drawing Standard Dryer .....                          | 17        |
| Function description.....                                     | 18        |
| Available options.....  | 20        |
| <b>Installation.....</b>                                      | <b>22</b> |
| Preconditions for installation .....                          | 22        |
| Connect piping.....   | 23        |
| Installing the electrical connection.....                     | 24        |
| <b>Start-up .....</b>   | <b>26</b> |
| Requirements for initial start-up .....                       | 26        |
| Setting times of the operating phases .....                   | 27        |
| Overview of operating and control elements .....              | 27        |
| Emergency shutdown .....                                      | 30        |
| Start up dryer.....   | 30        |
| Changing cycle mode .....                                     | 32        |
| <b>Monitoring dryer operation.....</b>                        | <b>34</b> |
| With dewpoint-sensing control (optional).....                 | 34        |
| <b>Shutdown and restart dryer.....</b>                        | <b>35</b> |
| Emergency shutdown .....                                      | 36        |
| Depressurising and shutting down the dryer .....              | 36        |
| If work is to be carried out on the electrical system .....   | 36        |
| Restart.....  | 37        |

|  |           |
|--|-----------|
| <b>Maintenance and repair of the dryer.....</b>        | <b>38</b> |
| Notes on maintenance.....                              | 38        |
| Regular maintenance intervals .....                    | 39        |
| Instructions for use of the dongle.....                | 40        |
| Daily maintenance tasks.....                           | 41        |
| Maintenance work to be completed every 12 months ..... | 41        |
| Notes on further maintenance work .....                | 44        |
| <b>Identify and eliminate faults .....</b>             | <b>45</b> |
| Summary of faults .....                                | 45        |
| <b>Index .....</b>                                     | <b>48</b> |
| <b>Annex with technical documentation .....</b>        | <b>50</b> |
| Technical data.....                                    | 51        |
| Replacement and wear parts list .....                  | 52        |
| Flow diagram.....                                      | 54        |
| Logic control diagram .....                            | 55        |
| Dimensional drawing .....                              | 57        |

---

# General information

---

## Manufacturer's details

### Name and address



*Parker Hannifin Manufacturing Germany GmbH & Co. KG  
Gas Separation and Filtration Division EMEA*

Im Teelbruch 118  
D-45219 Essen

Phone        ++49 (0) 2054 934-0  
Fax            ++49 (0) 2054 934-164

Internet      <http://www.parker.com>

---

## Details on the dryer

### Standard equipment

Standard dryer\*, consisting of

- 2 vessels, filled with desiccant
- 1 upstream filter
- 1 downstream filter
- Piping and muffler
- Control system

Associated documents

- Operating instructions (present)
- Technical documentation (see annex)
- Circuit diagrams (separate document)
- Operating manual for installed filters (separate document)

### Notes on supplementary documents

Supplementary documents such as operating manuals for options or pertaining components must always be heeded. They contain additional information, e.g. regarding maintenance, and are therefore necessary for safe operation of the plant.

---

\* Planned dryers may be equipped with special components

## About these operating instructions

---

These operating instructions contain basic information on the safe use of the dryer.

### Characters and symbols used

- ▶ Work steps that you have to carry out in the sequence stated are marked by black triangles.

Lists are marked by a small box.

#### **Note:**

**These notes provide you with hints and information on the safe and efficient handling of machines and devices.**



#### **Warning!**

**These safety notes warn against damage to property and help you to avoid such damage.**



#### **Danger!**

**These danger notes with a grey background warn against personal injury and/or danger to life and limb; danger notes help you to avoid serious or life-threatening situations for yourself and/or third parties.**

### Target group of these operating instructions

These operating instructions are intended for all persons working on and using the dryer. We assume that all such persons are specialist personnel, e.g. fitters or electricians.

### Operating instructions: handling

These operating instructions must be continuously available at the site where the dryer is used. We recommend to prepare a copy and to keep the same in a safe and freely accessible place next to the dryer. Keep the original document in a safe place.



## For your own safety

The dryer has been built in accordance with the state of the art and the recognized technical safety regulations. Nevertheless, there is a risk of personal injury and damage to property when the dryer is used, if it is operated by non-qualified personnel, not used within its intended design specifications, is repaired or maintained incorrectly.

### Note:

**For your own safety and to prevent machine damage, please note the information and safety notes in these operating instructions when working with the dryer.**

## General safety notes



### Warning against sudden air ejection

When the hollow section vessels are depressurised, air flows suddenly out of the sound absorber.

- This causes a sudden loud cracking noise.
- Due to particles carried in the air flow, there is a very considerable risk of eye injury.

When working on the dryer, always wear eye and ear protection equipment.



Hazard due to a sudden release of pressure!

Never remove any parts of the dryer, or manipulate the same in any way, for as long as the plant is still pressurised! A sudden escape of pressure may cause serious injuries.

Before carrying out any work on the dryer, first depressurise the plant.



Risk of injury due to voltage-carrying parts!

The electrical supply cable and external power lines are live even after the dryer is switched off and, in the event of body contact, may cause serious injury! Before carrying out any work on the electrical system, the electrical supply cable and all external power lines must be made voltage-free!

## Personnel qualification

Only authorized and qualified specialist personnel may be tasked with the work on the dryer described in these operating instructions.

## Conversions and modifications

Without prior approval by the manufacturer, no conversions and modifications must be made to the dryer! Any non-approved modifications may restrict the operational safety of the dryer and cause damage to property or personal injury.

## Handling drying agents

The drying agents are perfectly safe when in an unused condition. However, when filling and emptying the vessels with drying agents, increased dust generation may occur. Please comply with the following instructions:

When filling drying agents into the vessels, wear a dust mask and eye protection!

If a spillage occurs, any spilt drying agent must be taken up immediately. There is a risk of skidding!

## Disassembly and disposal

Dispose all parts of the dryer, the drying agent, and all other operating materials in an environmentally safe way and in accordance with all current statutory regulations.

## Signs, instruction plates and danger zones at the dryer

---



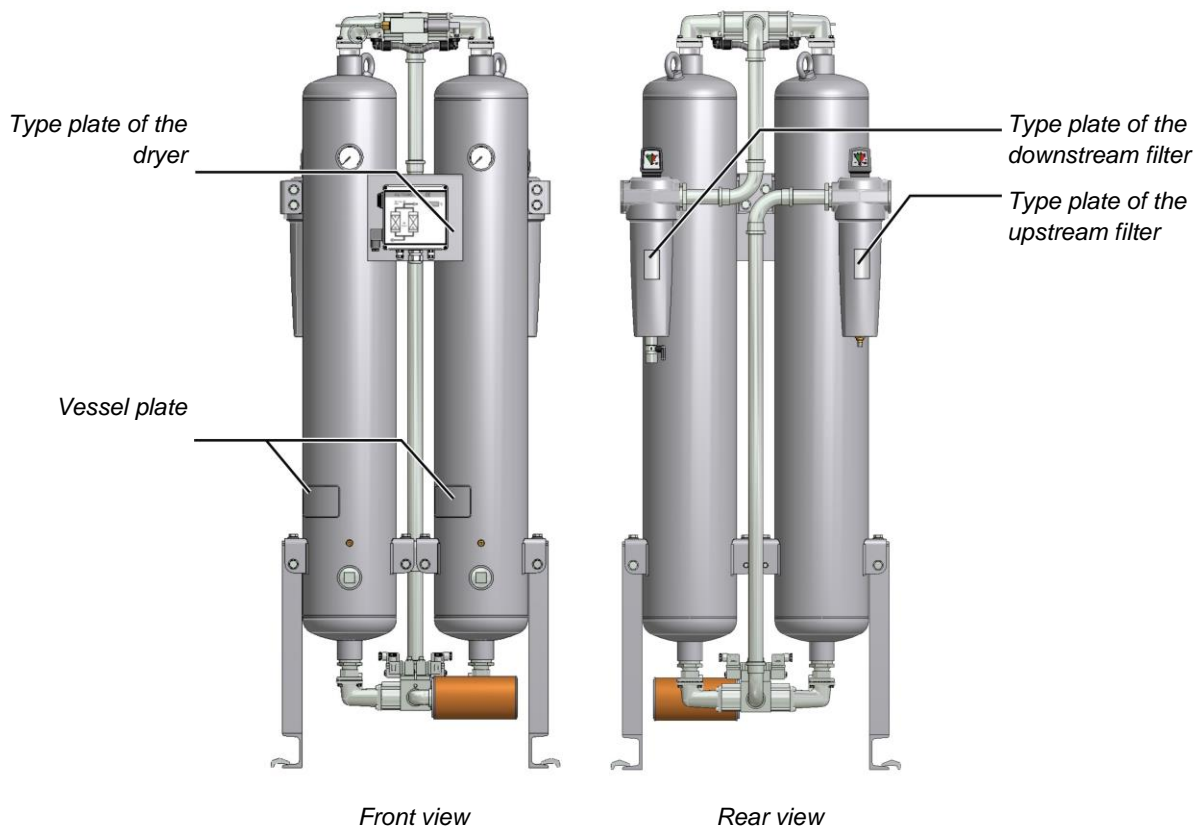

### Signs and instructions

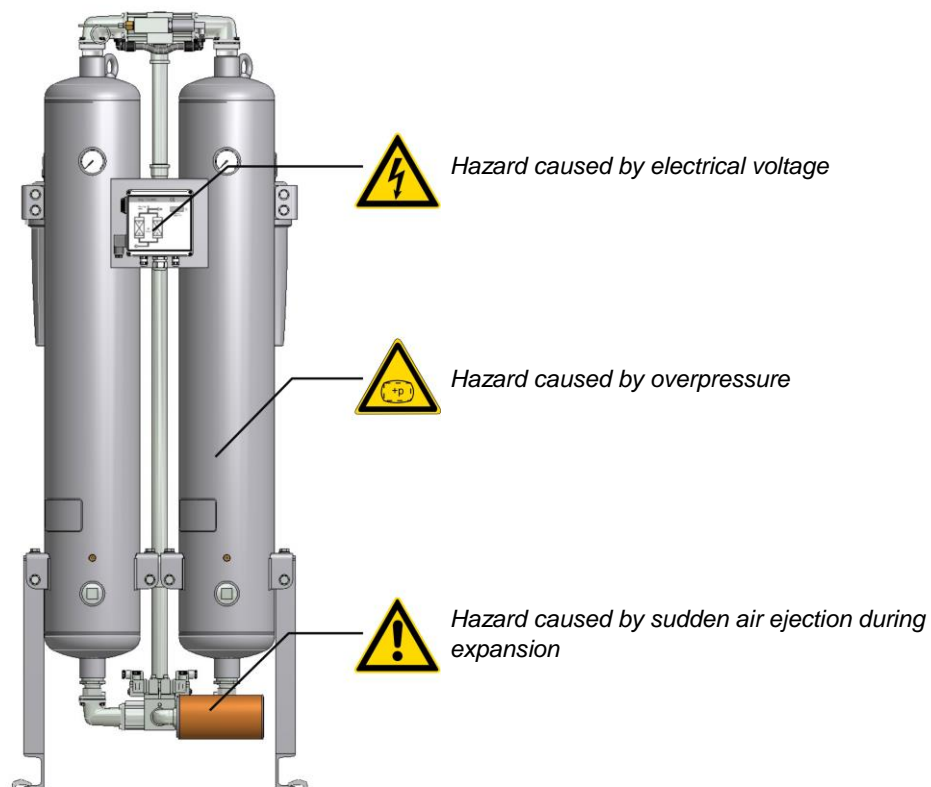

Please note the above plates and instructions attached to the dryer. Ensure that they are not removed and are always readable.

## Hazard areas on the dryer



| Hazard area  | Symbol in operating instructions  |
|--|---|
| <p><b>Warning against hazardous electrical voltage</b></p> <p>Different parts of the dryer carry electrical current. These parts may be connected, opened, and maintained by authorized specialist personnel only.</p>   |  |
| <p><b>Warning against overpressure</b></p> <p>The entire dryer is under pressure. Before commencing any work, the plant must be depressurised.</p>   |  |
| <p><b>Warning against sudden air ejection</b></p> <p>When the vessels are depressurised, air flows suddenly out of the sound absorber:</p> <ul style="list-style-type: none"> <li>■ This causes a sudden loud cracking noise.</li> <li>■ Due to particles carried in the air flow, there is a very considerable risk of eye injury.</li> </ul> <p>When working on the dryer, always wear eye and ear protection equipment.</p> |  |
| <p><b>Skid risk</b></p> <p>When emptying and filling the vessels with drying agent, there is a risk of skidding caused by spilt drying agent.</p>  |  |

## **Intended use of the dryer**

---

The dryer is exclusively intended for drying compressed air. Depending on defined input conditions, it dries compressed air for industrial use.

The dryer is designed for compressed air, which is free from aggressive water, oil, and solid matter constituents.

As standard, the dryer is intended to be sited within a building and protected against the weather.

The dryer may be operated only in accordance with the data on the type plate and in accordance with the contractual conditions.

## **Suspected misuse**

The dryer must not be misused as a climbing aid! Pipes, valves, and similar fittings have not been designed for such loads. They could fracture, tear off, or become damaged in another way.

## Transportation, installation and storage



### **Danger due to incorrect transportation!**

**The dryer must be transported by authorized and qualified specialist personnel only. During transportation all applicable national regulations for accident prevention must be complied with. Otherwise there is a risk of personal injury.**

**Always adhere to the stickers and notes on the packaging of the dryer!**

- Only use suitable and technically perfect lifting gear with a sufficient carrying capacity.

During transportation the dryer must be carefully secured against falling over.

The manufacturer will not be liable for any damage caused by incorrect storage or incorrect transportation. Please note therefore the following instructions as well as the storage instructions on page 16.

## Information on transportation packaging

Depending on the type of transportation, the dryer is delivered in different types of packaging:

All transportation types: the apertures of the dryer are closed off by means of plugs.

In addition, when transportation is effected by air: the dryer is packaged in a wooden box.

In addition, when transportation is effected by ship: the dryer is packaged in a film material and in a wooden box.

### **If the packaging is undamaged**

- ▶ The undamaged packaging should be removed only at the final installation site, as it offers protection against any weather influences.

## What to do in the case of transport damage occurring?

- ▶ Check whether only the packaging or the dryer itself were damaged.
- ▶ Inform the haulier immediately in writing of any damages.
- ▶ Contact the manufacturer urgently in order to report the damage.



### **Warning!**

**A damaged dryer must not be taken into operation! Damaged components may lead to functional faults and possibly cause further damage.**

## Transporting and installing the dryer

### Requirements for the installation site

The conditions at the installation site have a large influence on the functional capability of the dryer and the service life of the drying agent. In order to ensure a mode of operation, which is as continuous as possible, and low maintenance, the installation site must meet the following requirements:

- The installation site must be located within a building. Protect the dryer against moisture.
- The ambient temperature must not drop below +1,5 °C (34,7 °F).
- Heed the dryer's noise emission when selecting the installation location.
- The installation area must be level, firm and vibration-proof. It must have the necessary carrying capacity for the weight of the dryer. The weight of the dryer is specified in the technical data section of the annex.
- The dryer should be installed with sufficient spacing at the top, sides, and rear, in order to be able to carry out maintenance work and change the drying agent without any hindrances (see figure).

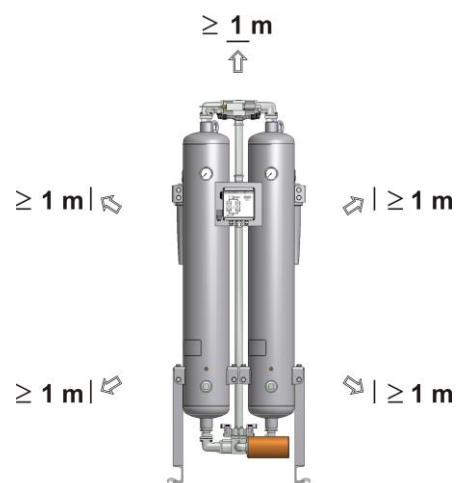

Necessary spacing at the top and sides  
= min. 1 m

If in doubt, the installation site must be inspected by specialists. If you have any queries in this regard, please contact the manufacturer (for details see page 7).

### Transportation using lifting or forklift trucks



#### Warning against damage to property!

The dryer is delivered standing on its side on a transportation pallet. Top and sides have not been designed for mechanical loads. Therefore do not place any load onto the top face. Do not stack.

Therefore, always transport the dryer on a lifting or forklift truck.

The dryer should only be transported in an upright position.

- ▶ Secure the dryer on the lifting or forklift truck against sliding movements.
- ▶ Transport the dryer to its installation site.

## Installing the dryer



### Caution!

Always use the lifting lugs at the top of the tank to lift the dryer. Use a lifting beam with a suitable spacing for this purpose. This will ensure the tanks cannot come in contact with the upper pipe bridge and thus damage it.

- ▶ Remove the packaging of the dryer.
- ▶ Attach suitable lifting gear to the transport lugs of the vessels (see figure I).
- ▶ Raise the dryer (see figure II) and remove the transportation pallet.
- ▶ Place the dryer at its installation site.

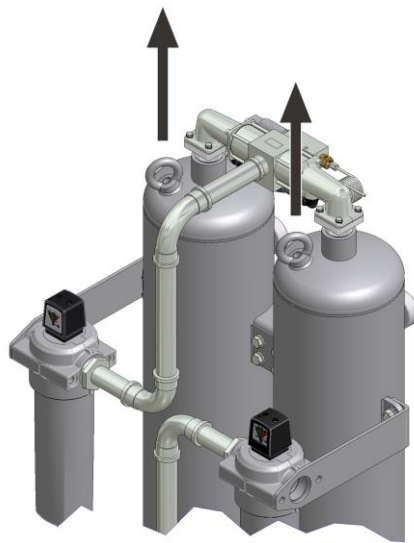

I: Transport lugs on pressure vessel

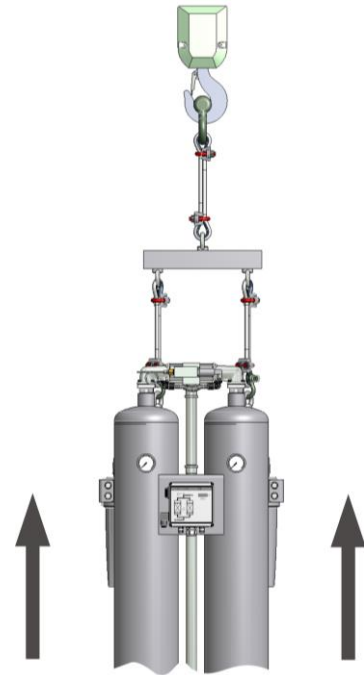

II: Installing by crane

## Anchoring the dryer

- ▶ Use suitable attachment material to anchor the dryer to the floor.
- ▶ *In the case of vibrating floors:* place the dryer on suitable vibration dampers.

## Storing the dryer

---

If the dryer is to be stored for an extended period of time, the storage location must meet the following conditions:

The dryer must not be stored in the open air.

The storage room must be dry.

The storage room must be free from dust or the dryer must be covered by a protective sheet.

The storage room must have an ambient temperature of at least +1 °C (33,8 °F).

In order to store the dryer proceed as follows:

- ▶ Take dryer out of operation as described on page 36.
- ▶ Ensure that the compressed air inlet valve installed by the owner, and the installed compressed air outlet valve installed by the owner, are both closed, and that the dryer is depressurised.
- ▶ Disconnect dryer from the compressed air system.
- ▶ Disconnect the dryer from the electrical power supply and all external lines.
- ▶ Use film material or similar to close the compressed air inlet apertures and compressed air outlet apertures on the dryer in order to protect them against contamination.
- ▶ If possible cover dryer with a protective sheet.

The dryer can now be stored for long periods.

**Note:**

**If you wish to take the dryer back into service after an extended period of storage, please proceed as described for its first commissioning and start-up (see page 31).**

### Store drying agents

- ▶ Do not store drying agents in the open air.
- ▶ Protect drying agents against humidity.



# Technical product description

## Summary Drawing Standard Dryer\*

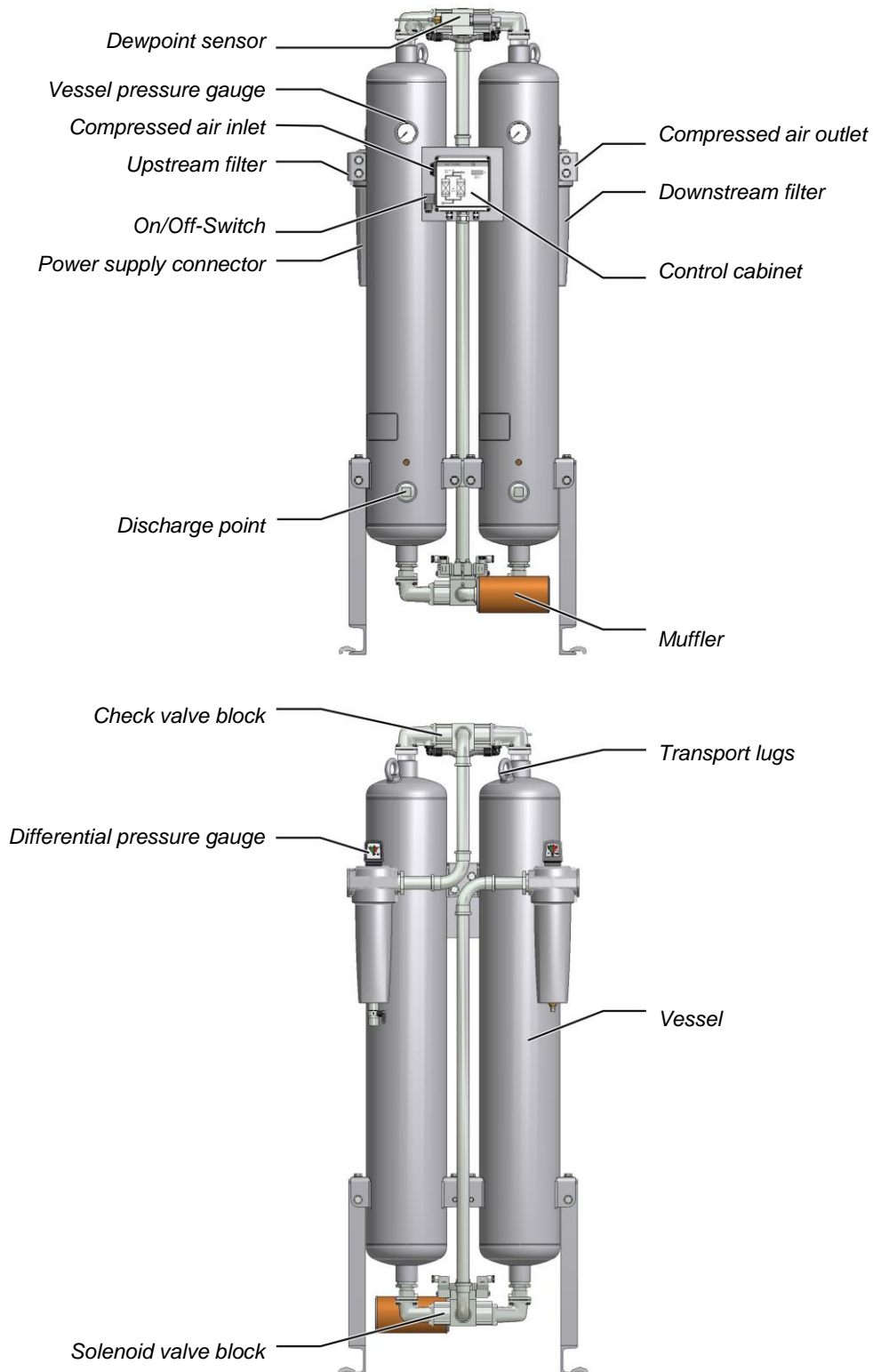

\* Planned dryers may differ in their configuration (in this case, refer to the enclosed dimensional drawing)

## Function description

The dryer dries the compressed air supplied by the compressor and makes it available for industrial use.

Upstream filters clean the compressed air and remove dust, dirt, oil, and water droplets, before the compressed air reaches the dryer. Thus, an upstream filter is also used for extending the service life of the drying agent.

Downstream filters clean the compressed air from drying agent abrasions, before it is fed into the compressed air system.

The two vessels contain an extremely porous drying agent by means of which humidity is removed from the compressed air and stored just as in a sponge. The stored humidity is then removed again from the drying agent and re-introduced into the ambient environment.

To this end, the two vessels alternate between different operating modes. Whilst in one vessel, compressed air is de-humidified (adsorption), in the other vessel the humid drying agent is prepared for another charge (regeneration). These two states, which run in parallel during compressed air preparation, are described below.

### Adsorption

Via a compressor, humid compressed air is supplied to the upstream filter. From here, the compressed air flows upwards through the absorption vessel, which is pressurised. In so doing, the drying agent dehumidifies the air. The dry compressed air is supplied to the pipe network via the downstream filter.

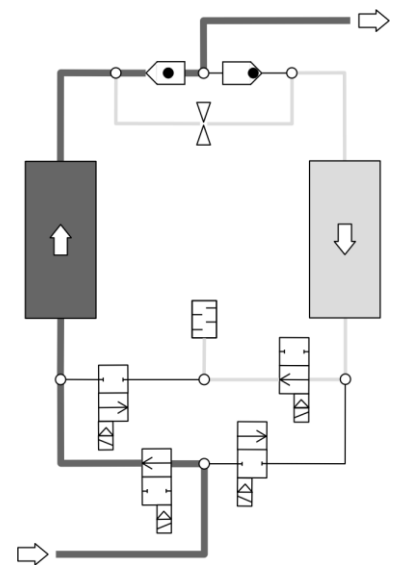

Here, adsorption is shown in the left vessel.

### Regeneration (running in parallel to the adsorption)

At the same time the other vessel is prepared for a renewed take-up of humidity. This process is called regeneration.

The regeneration is subdivided into three phases: expansion, dehumidification, and pressure build-up.

With the *dewpoint-sensing control* option, the regeneration phase is followed by a standby phase.

### Expansion phase

During the expansion phase the pressure in the right vessel is released via the muffler down to ambient pressure within just a few seconds. The outflow of the compressed air becomes noticeable due to a sudden powerful flow noise at the muffler.

### Dehumidification phase

Prior to being released into the pipe network, dried compressed air is bled by means of an orifice plate. This separate regeneration air flow is fed through the depressurised vessel. The humidity stored in the drying agent is taken up by the air flow and expelled into atmosphere via the muffler.

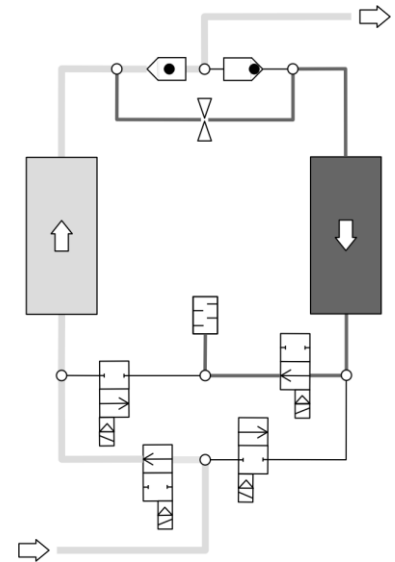

*Here, regeneration is shown in the right vessel.*

### Pressure build-up phase

After dehumidification the pressure in the regenerated hollow section vessel is built up to operating pressure, so that the switchover from regeneration to adsorption can take place at operating pressure level.

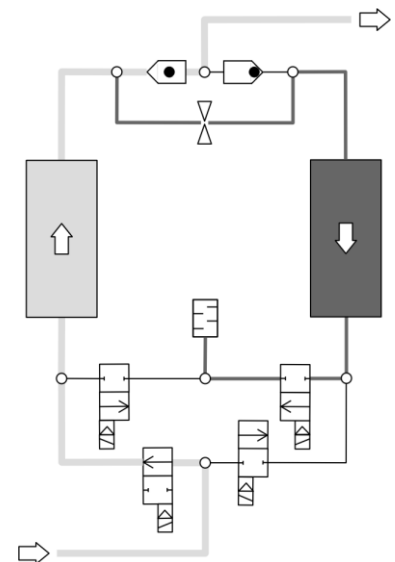

*Pressure build-up*

### Standby phase (only with the dewpoint-sensing control option)

When in standby phase, the fully regenerated vessel is ready for absorption operation. The system is switched to this vessel, as soon as the measured dewpoint at the compressed air outlet has reached the set dewpoint value for switchover.

## Switchover

When the drying agent in the adsorbing vessel has taken up a sufficient level of humidity, then the switchover between the vessels will be effected between the vessels. Following switchover, the above-described process is repeated, with the adsorption and regeneration now taking place in the respective different vessel.

## Available options

---

The following options are available for the dryer:

- Start-up device
- Signalling contacts of control system
- Regeneration gas recirculation
- Dewpoint-sensing control
- Fine filter muffler
- Nozzle kit

### Start-up device

A start-up device basically consists of a pressure holding device, which is located at the rear of the dryer. The pressure holding device ensures that pressure can build up in the dryer and adsorption take place.

It is always required when an empty compressed air reservoir or an empty compressed air system must be filled downstream of the dryer (e.g. following weekend shutdowns and when the pressure in the compressed air system can frequently drop below the stated operating pressure).

### Signalling contacts of the control system

The control system is equipped with a digital input for the synchronised operation with a compressor. This feature allows for synchronised and thus efficient dryer operation with discontinuous compressor operation.

Compressor synchronisation helps reduce energy costs, as the dryer can be operated independently of the compressor.

The compressor synchronisation controller is a higher-level controller than the pressure dew point controller (see below). When both options are in place, the compressor synchronisation controller is treated as the prime controller.

The control system can also be equipped with an optional operation signalling contact with which the dryer operation can be monitored from an external device. Dryers with the optional *dewpoint-sensing control* are equipped with such a contact as standard. It is used for the transmission of operating signals and for the output of dewpoint alarms.

### Regeneration gas recirculation

When the compressor is switched off, the regeneration gas recirculation serves to continue regeneration provided a sufficiently large compressed air volume is present downstream of the dryer. The regeneration process must be continued and ended so that the drying agent does not become unusable prematurely.

Regeneration gas recirculation depends on the properties of the installed compressed air network and should be discussed with the manufacturer beforehand.

## Dewpoint-sensing control

With a dewpoint-sensing control system, you can operate the dryer in fixed or variable cycles. In the fixed cycle, switchover is effected after a fixed time period (usually after 5 minutes). In the variable cycle, the switchover is effected in relation to the dew point reached and the charging of the drying agent. The adsorption time in the variable cycle amounts to 60 minutes maximum.

## Fine filter muffler

A fine filter muffler is used to reduce the noise emission of the dryer to lower levels than the standard muffler can provide. If installed, the fine filter muffler replaces the original installed muffler.

## Nozzle kit

In the case that the operating pressure deviates from the standard design pressure (7bar<sub>e</sub>) it is possible that the amount of necessary regeneration air changes. This effect may have a negative impact on the cost-effectiveness of the dryer. To prevent this, it is possible to replace the built in regeneration air nozzle by a nozzle with a modified bore. This replacement optimizes the regeneration air consumption and therefore restores the energy efficiency of the dryer. To receive more information on this conversion, please contact the manufacturer.

# Installation



**Only authorized and qualified specialist personnel may carry out work on pipes and electrical systems.**

As soon as the dryer has been set up at its installation location, you can install the compressed air infeed and outlet lines and make the electrical connections.

## Preconditions for installation

---

For a correct installation the following preconditions must be met on the part of the owner.

Connections and lines for the infeed and outfeed of compressed air must be provided.

A compressed air inlet valve as well as a compressed air outlet valve must be installed by the owner, so that the dryer can be installed and maintained in a depressurised condition (see also the installation example on page 23).

All pipes, couplings, and connections must have the correct diameter and match the operating pressure.



**Hazard caused by exceeding the limit values!**

**A safety device must be provided in order to protect against the maximum permissible operating pressure from being exceeded.**

**The safety device must be installed so that the dryer is reliably protected from exceeding the maximum permitted operating pressure even when the temperature of the compressed gas increases.**

The data required to meet these preconditions are contained in the technical documentation attached in the annex.



**Warning!**

**If the above preconditions are not complied with, a safe operation of the dryer cannot be assured. Also, the functionality of the dryer may be detrimentally affected.**

## Connect piping

In order to ensure that the dryer operates optimally, the dryer must be assembled into the compressed air system free of all stresses.

- ▶ Ensure before connection that all infeed and outfeed compressed air lines and valves are clean and undamaged.
- ▶ Check the bolt connections and retighten if necessary, as they could have worked loose during transportation.
- ▶ Remove plugs on the pressure inlet and outlet.



**All piping must be free from any stress and tension whatever!  
Pipes subject to stress may burst due to the load placed on them during operation. This may cause damage to property and personal injury.**

- ▶ Use steel pipes to connect the dryer to the compressed air system.

The following figure shows an installation example.

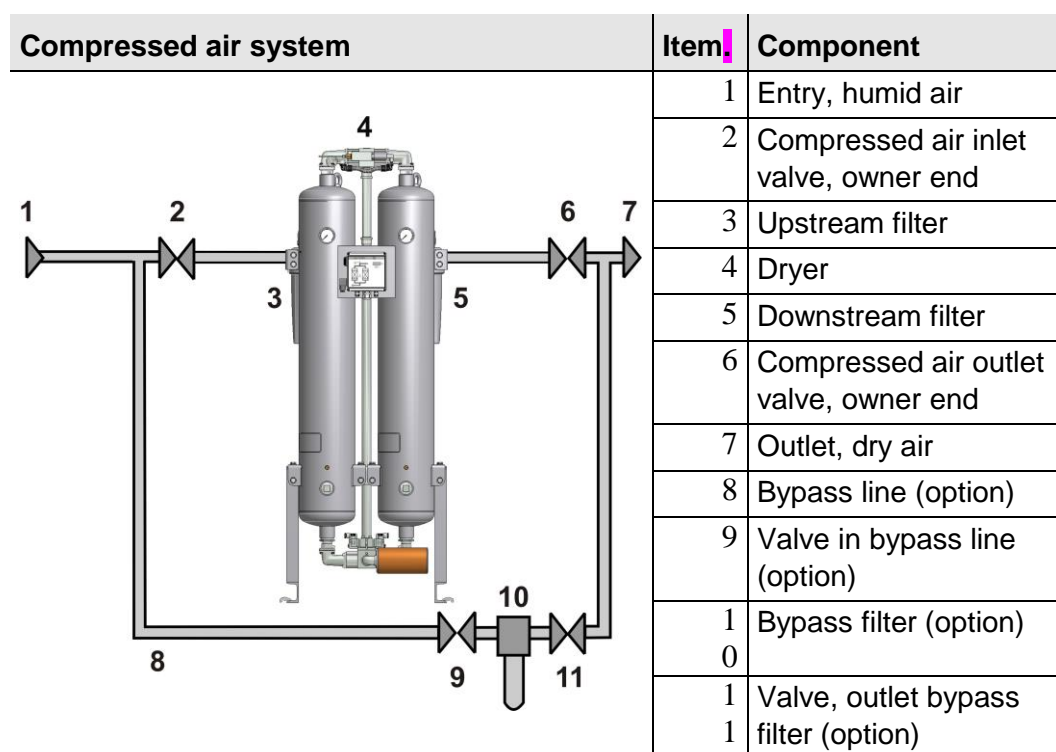

Example of an installation with bypass line

- ▶ The connection lines for the upstream filter (3) are to be installed at a slight incline in the direction of the upstream filter.
- ▶ One shutdown valve each (2, 6) is to be installed at the compressed air inlet and outlet ends of the dryer.
- ▶ *If you fit a bypass line (8) with additional shutdown valve:*  
Fit the line such that, when carrying out maintenance work on the dryer, the line system can continue to be supplied with compressed air.

## Installing the electrical connection



### Warning against electrical voltage

**Only qualified specialist personnel may carry out work on the electrical system!**

### Installing the supply cable

The components of the dryer have been connected to the control cabinet at the factory. You only need to connect the control cabinet to the electrical supply cable.

The switchbox is provided with a connector where electrical power must be connected.

- ▶ Ensure that the cross-section of the electrical supply cable corresponds to the power rating of the dryer and the electrical voltage provided by the customer.
- ▶ Make the electrical supply cable to the dryer voltage-free.
- ▶ Secure the electrical supply cable to the dryer against switch-on.
- ▶ Undo bolt (1) on the connector and withdraw connector with seal from the switchbox.
- ▶ Use a suitable tool to remove the terminal block from the connection box.
- ▶ Undo the PG union and pull the cable through the aperture (3). The exposed phase ends should not be longer than 35 mm max.

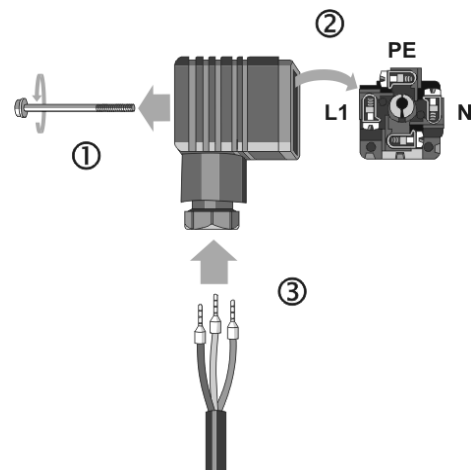

Connect electrical cable to device adapter

- ▶ Now make the cable connection as follows:
  - Earth to terminal PE
  - L1 to terminal 1
  - N to terminal 2

Terminal 3 is not used.

- ▶ Fit terminal block into the connector and use bolt to remount the connector with seal on the switchbox.
- ▶ In all phases the dryer must be protected against short circuits by means of fuses.
- ▶ In order to relief cable strain, re-tighten the PG union.



## Connecting the external signalling lines

### For compressor synchronisation

The controller is fitted as standard with a digital input which makes the dryer regeneration dependent on operation of the compressor (switch S1 on the controller's circuit board, see also figure below).

If switch S1 is in the ON position, operation of the compressor and dryer regeneration run synchronously: When the compressor is stopped, the dryer regeneration also stops. When the compressor is restarted, regeneration also restarts.

If switch S1 is in the OFF position, any regeneration process which has been started, is always continued until completed.

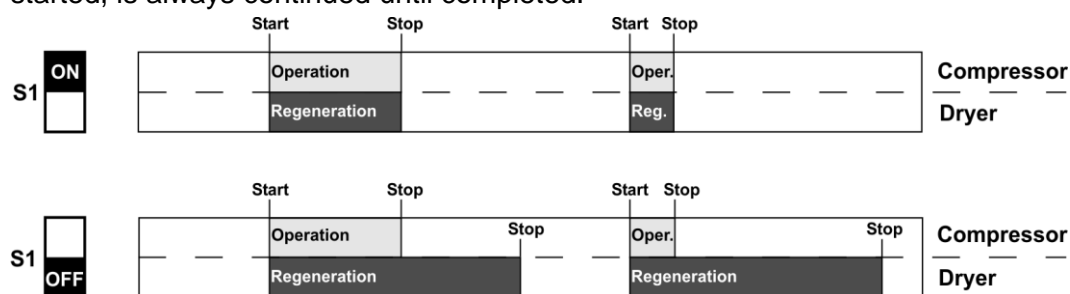

To install the external line, proceed as follows:

- ▶ Connect the signalling line to the potential-free busbar connection of the compressor to terminals 1 and 2 on the control board (see circuit diagram).

#### Note:

**The compressor synchronisation controller is a higher-level controller than the pressure dew point controller. When both options are in place, the compressor synchronisation controller is treated as the prime controller.**

### For operation monitoring system (optional)

Operators have the option to connect the dryer to a fault signalling system, connecting the respective line to a potential-free operation signalling contact. With this option, the following statuses and events can for example be transmitted to a remote control room:

Dryer on (contact made)

Power supply disconnected (no contact)

Dewpoint alarm (only with *dewpoint-sensing control* option, no contact)

To install the external lines, proceed as follows:

- ▶ Connect the lines of the fault signalling system to relay K5 (see circuit diagram).

## Check bolt connections

Before the initial start-up:

- ▶ Check all unions and bolt connections as well as the terminals in the control cabinet for secure seating; re-tighten if necessary.

## Start-up



### Warning!

**The dryer must be taken into operation by trained personnel only! Untrained personnel does not have the required knowledge. Such personnel might cause serious faults.**

### Note:

**You can order the initial commissioning and start-up from the manufacturer and have your personnel trained by the manufacturer. For telephone number, see page 7.**

Carry out all prescribed tests and checks.

Before start-up, ensure that no tools or other foreign parts have been left lying in a part of the dryer where they might pose a hazard to the dryer being started up.

## Requirements for initial start-up

---

For the first start-up the following preconditions must have been met:

The pipe system is free from

- scales
- thread abrasions
- welding beads and
- other contaminations.

All shutdown valves

- of the compressed air inlet and outlet valves installed by the owner
  - in the bypass line (if available)
- are closed.

The dryer is correctly sited and installed.

### Checks before start-up

Ensure that

all pipe, cable and bolt connections on the dryer have been retightened,

no pipes chafe against body edges,

all mountings are perfectly secure,

the needle valve of the oil indicator is closed,

the electrical connections are in safe contact and in good condition,

owner-end and pressurised parts such as safety valves or other devices are not blocked up by dirt or paint,

all compressed air system parts which are pressurised (valves, hoses etc.) are free from wear symptoms and defects.

## Setting times of the operating phases

In its standard version the dryer is delivered with a time-dependent control system. The phase sequence occurs in a fixed cycle.

With the optional dewpoint-sensing control, the dryer can also be operated at variable cycles (depending on the dewpoint).

The following table provides information on the duration of the individual phases.

| Phase duration                    | Fixed cycle | Variable cycle    |
|-----------------------------------|-------------|-------------------|
| Adsorption                        | 5 min       | 60 min, maximum   |
| Regeneration, total               | 5 min       | 5 min             |
| – of which: expansion time        | ~ 0.2 min   | ~ 0.2 min         |
| – of which: dehumidification time | ~ 4 min     | ~ 4 min           |
| – of which: pressure build-up     | ~ 1 min     | ~ 1 min           |
| Standby                           | —           | ~ 55 min, maximum |

## Overview of operating and control elements

### ON/OFF switch

The ON/OFF switch (2) is located to the side of the switchbox and above the mains plug (1, see figure):

- If it is set to **0**, the power supply is disconnected and the dryer is switched off. The main valves are (V1, V2) are open, while the expansion valves (V3, V4) are closed. This means that the air can circulate in the main processing direction, even if the dryer is switched off.
- If the switch is set to **I**, the dryer is switched on and begins to operate in fixed cycle mode (i.e. time-controlled).
- If the switch is set to position **II**, the dryer is switched on and begins to operate
  - with compressor synchronisation
  - in variable cycle mode (i.e. dewpoint-controlled).

Position **II** is only relevant for operation with the optional *compressor synchronisation* and/or *dewpoint-sensing control*.

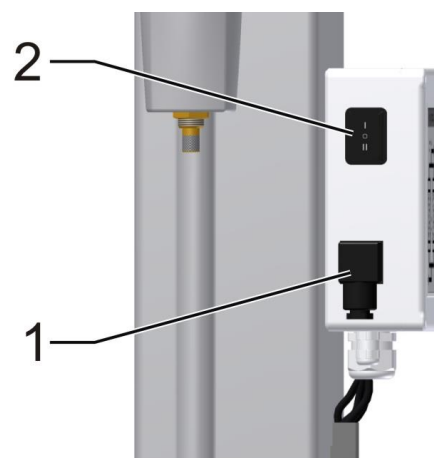

Switchbox with ON/OFF switch

## Display panel

The display panel at the switchbox is equipped with LEDs (light emitting diodes) and a digital display, indicating the operating status of the dryer:

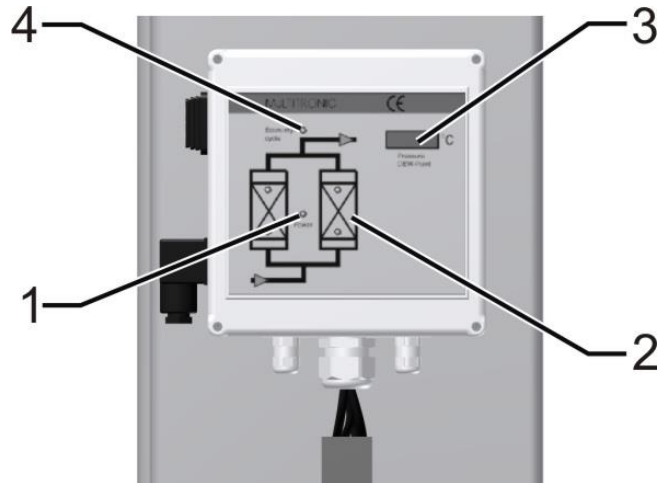

Display panel at the switchbox

### LED Power (1)

LED is on when dryer is switched on.

### Flow diagram (2)

The current operating phases of the dryer are indicated by means of 4 LEDs:

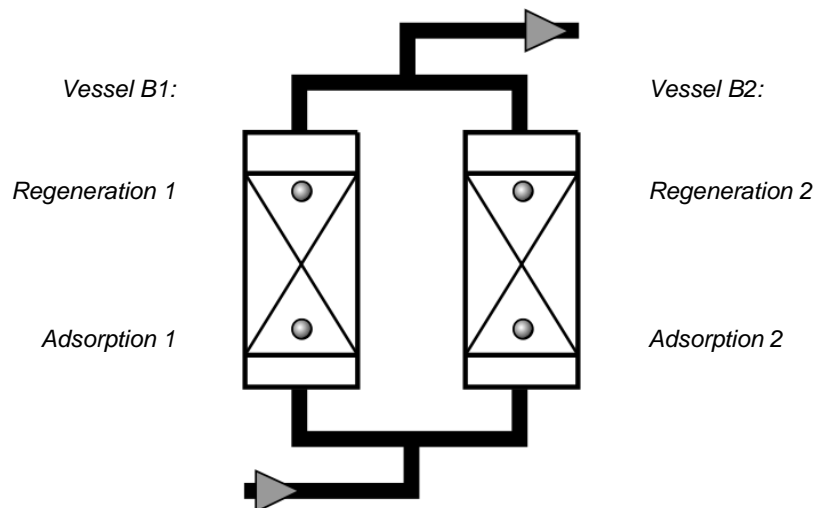

Depending on the operating phase, the following LEDs might be on simultaneously:

*Adsorption B1 and regeneration B2 or  
regeneration B1 and adsorption B2.*

### Digital display (3)

The digital display shows the individual programme steps and the respective remaining time. For details regarding the sequence of the individual processing steps and their duration, please refer to the logic control diagram, page 55.

| Display |     | Explanation  |
|---------|-----|--|
| 2       | 215 | Default display: The figure to the left indicates the current processing step; the figure to the right shows the remaining time in seconds.<br><br>In this example, step 2 is being completed, whereby there are 215 seconds remaining.  |
| SEr.    |     | After 8000 operating hours, "SEr." (service) is displayed for periods of 1 minute, alternating with the default display.<br>Notify the service personnel of the manufacturer, as a routine service is now due.   |
| - 25    |     | With the <i>dewpoint-sensing control</i> option, the display shows the currently measured dewpoint instead of the default data. The range of display is -100 °C (-148 °F) to +20 °C (68 °F).<br>If the measured dewpoint exceeds the preset alarm limit (5 °C (41 °F) above the switchover value), the displayed dewpoint value is flashing. |

With the optional *dewpoint-sensing control*, the following error messages might be displayed:

| Display            | Cause  |
|--------------------|--|
| +20                | ■ Upper measuring range limit exceeded   |
| 999                | ■ Dewpoint sensor defective  |
| sens<br>or<br>-999 | ■ Dewpoint sensor not powered<br>■ Cable defective or disconnected<br>■ Sensor defective |

#### LED *Economy cycle* (4)

This LED is only relevant in units that are equipped with the optional *dewpoint-sensing control*. The diode lights up when the dryer is switched on and in the standby phase and no regeneration air is required.

## Vessel pressure gauge

On both vessels, pressure gauges are fitted which show the operating overpressure. The operating overpressure indicates the operating phase of the relevant vessel:

- During adsorption the pressure gauge should indicate the nominal operating overpressure.
- During regeneration the indication of the pressure gauge on the regenerating vessel
  - should decrease in the expansion phase from operating overpressure to 0 bar overpressure,
  - indicate an overpressure of 0 bar in the dehumidification phase.

With an increasing duration of operation, a higher overpressure can be indicated during regeneration. This overpressure during regeneration is also designated as dam pressure.

- The dam pressure should not exceed 0.3 bar, otherwise read the instructions on page 41.
- During the pressure build-up phase the indication on the pressure gauge should again rise to operating overpressure level.

## Emergency shutdown

---

To emergency shut-down the dryer heed to the following instructions:

- ▶ Close shut off valves upstream and downstream of the dryer (if applicable)
- ▶ Disconnect the electrical power supply (i.e. by switching the **ON/Off** switch to **0**).
- The dryer is now off-line.
- ▶ If applicable, depressurise the dryer now.

Before re-commissioning the dryer ensure that the emergency situation has been solved and that the dryer is not damaged.

Never commission a damaged dryer!

## Start up dryer

---



### Warning against sudden air ejection!

**During expansion the pressure is released suddenly through the muffler:**

- A loud cracking noise occurs which can injure your hearing.
- Particles carried in the air flow act like bullets and can injure your eyes or skin.

**Always wear eye and ear protection, therefore, when you are in the vicinity of the dryer!**



### Hazard due to a sudden release of pressure!

**Never remove any parts of the dryer, or manipulate the same in any way, for as long as the plant is still pressurised! A sudden escape of pressure may cause serious injuries.**

**Before carrying out any work on the dryer, first depressurise the plant.**

- The more powerful the dryer is, the more noise may be generated during operation. Therefore, the operator must provide suitable protective equipment (e. g. ear protection).
- Only operate the dryer within the permissible limits. By operating the dryer in conditions for which it has not been designed, functional faults may be caused.
- Depending on the size of the dryer and the compressed air network and the respective legal requirements in your country, it may be necessary to perform initialisation according to the directive for pressure equipment.
- Check the dryer regularly for externally visible damage and defects. Any changes, even in its operating behaviour, must be reported immediately to the competent office or person.

- In the event of an emergency or if a safety-relevant disruption occurs (e.g. escaping compressed air, defective component), the dryer must be shut down immediately as described in the section on page 36). The unit may only be restarted after all defects have been eliminated.

## Open compressed air supply and switch on dryer

For start-up, please proceed in the sequence shown here.

- ▶ Ensure that the compressed air inlet and outlet valves installed by the owner are closed (see installation example on page 23).
- ▶ Ensure that the compressed air system upstream of the dryer is pressurised. If necessary, pressurise (switch on compressor).



### Slowly open compressed air inlet valve!

**Avoid sudden pressure build-up in any circumstance! If pressure builds up too fast, this may cause damage to the dryer. Therefore, the compressed air inlet valve must always be opened quite slowly!**

- ▶ Slowly open the compressed air inlet valve, installed by the owner, upstream of the dryer.
- ▶ Switch on dryer: to this end, set the ON/OFF switch to I.

If the dryer is taken into operation for the first time, or after a change of drying agent, the following intermediate step is meaningful. In the case of a restart situation, the following intermediate step can be skipped.

### Operating the dryer for the first time (or after a change of drying agent) separately

Depending on the transportation and storage conditions, the drying agent in the vessels can already be loaded with humidity from the environment. At each first start-up it makes sense therefore to operate the dryer from some time separately from the compressed air system. This causes the drying agent in each vessel to be regenerated repeatedly and thus to be prepared optimally for the take-up of humidity.

#### Note:

**Depending on the pressure dew point to be achieved, we recommend to operate the dryer at first start-up without compressed air consumption:**

- for at least 4 hours at a pressure dew point of  $-25$  to  $-40$  °C or
  - for approx. 3 to 5 days at a pressure dew point of  $-70$  °C.

If you wish to take the dryer into operation in accordance with our recommendation, proceed as follows:

- ▶ Ensure that the compressed air outlet valve installed by the owner is closed.
- ▶ Keep the compressed air outlet valve closed for the time period recommended above.

Then the dryer can be taken into service in the compressed air system as described in the following section:

### **Operate dryer immediately in the compressed air system**

- ▶ Ensure that the compressed air system downstream of the dryer is pressurised or that a start-up device (option, see page 20) was installed into the compressed air system directly downstream of the dryer.  
The importance of this increases with the size of the compressed air system downstream of the dryer. Smaller compressed air systems can be pressurised also by means of compressed air fed through the dryer.



### **Slowly open compressed air outlet valve!**

**Avoid a sudden drop in pressure in any circumstance! If pressure drops too fast, this may cause damage to the dryer. Therefore, the compressed air outlet valve must always be opened quite slowly!**

- ▶ Slowly open the compressed air outlet valve installed by the owner. Observe the vessel pressure gauge of the pressurised vessel. The pressure should not drop below the operating pressure (if poss.). If necessary, keep the compressed air outlet valve in a slightly open position until the compressed air system downstream of the dryer has filled up completely; only then should the valve be opened fully.

Then the dryer has to be taken into operation within the compressed air system.

### **In the event of a fault**

In the event of an emergency or if a safety-relevant disruption occurs (e.g. escaping compressed air, defective component), the dryer must be shut down immediately as described in the section on page 36).

Then proceed as follows:

#### **Remedy fault**

- ▶ Look up possible cause of the fault, and how to remedy the same, in the table on page 45.
- ▶ Remedy fault.
- ▶ Repeat the start-up procedure.

## **Changing cycle mode**

---

### **When can I change cycle mode?**

If the dryer has been successfully commissioned and is equipped with one of the following options:

compressor synchronisation or  
dewpoint-sensing control

it can be set to *economy cycle mode*.

### **When should I change cycle mode?**

Cycle changes should be made during the pressure build-up phase and prior to switchover; during this phase, the pressure in both chambers is just below operating pressure so that a fast pressure build-up is prevented when the chambers are switched.



During this period, only the adsorption LED is on in the diagram, and the digital display shows step 4 or step 9 for the duration of 1 minute (see logic control diagram; not displayed with dewpoint sensing).

### Which cycle modes can I choose?

If the dryer is connected to a *compressor synchronisation system* and is equipped with the *dewpoint-sensing control* option, these two optional devices can only be started together. The compressor synchronisation has thereby precedence over the dewpoint-sensing control.

### With compressor synchronisation

If compressor synchronisation is enabled, the dryer can only be operated in conjunction with the compressor. As soon as the compressor is switched off, the dryer is automatically set to standby mode.

In standby mode, the control system remains on, and the dryer is ready for the next switchover, which is made as soon as the compressor is switched on.

**Note:**

**The compressor synchronisation controller is a higher-level controller than the pressure dew point controller. When both options are in place, the compressor synchronisation controller is treated as the prime controller.**

### With dewpoint-sensing control

Dryers equipped with dewpoint-sensing control operated in variable cycle mode, based on the measured dewpoint of the dried air at the compressed air outlet. As soon as a certain dewpoint is reached, as the drying agent in the absorbing chamber is saturated, the chambers are switched.

The dewpoint at which a switchover is made is preset at the factory.

### How do I change cycle mode?

- ▶ Wait until the dryer has reached the pressure build-up phase (phase prior to switchover).

One LED for *Adsorption B1/B2* is on in the flow diagram.

- ▶ Set the ON/OFF switch to position **II**.

The programme continues the cycle.

## Monitoring dryer operation

The dryer operates fully automatically. However, you should carry out the regular checks described in the Chapter *Maintenance and repair of the dryer*.



### Warning against sudden air ejection!

#### During expansion the pressure is released suddenly through the muffler:

- A loud expansion noise is caused which may damage your hearing.
- Particles carried in the air flow act like bullets and can injure your eyes or skin.

**Always wear eye and ear protection, therefore, when you are in the vicinity of the dryer!**

## With dewpoint-sensing control (optional)

### Display of dewpoint

If the dryer is equipped with a dewpoint-sensing control system, the digital display at the front of the switchbox shows the currently measured dewpoint. The range of display is  $-100\text{ °C}$  ( $-148\text{ °F}$ ) to  $+20\text{ °C}$  ( $68\text{ °F}$ ).

If the set dewpoint is exceeded, the system automatically completes a switchover between the vessels. The dewpoint at which a switchover is made is preset at the factory.

- ▶ After commissioning or extensive maintenance work, check the dewpoint display at the dryer.

Under certain circumstances, the desired dewpoint is only reached after prolonged operation.

### Error messages

If the measured dewpoint exceeds the preset alarm limit ( $5\text{ °C}$  ( $41\text{ °F}$ ) above the switchover value), the displayed dewpoint value is flashing. In addition, an error message can be issued through the potential-free busbar.

Error codes and their causes:

| Display                          | Cause  |
|----------------------------------|--|
| <b>+20</b>                       | <ul style="list-style-type: none"> <li>■ Upper measuring range limit exceeded</li> </ul>   |
| <b>999</b>                       | <ul style="list-style-type: none"> <li>■ Dewpoint sensor defective</li> </ul>  |
| <b>sens</b><br>or<br><b>-999</b> | <ul style="list-style-type: none"> <li>■ Dewpoint sensor not powered</li> <li>■ Cable defective</li> <li>■ Sensor defective</li> </ul> |

For instructions on how to eliminate faults, see chapter *Identify and eliminate faults*

# Shutdown and restart dryer

In the following cases, the dryer must be fully shut down and depressurised:

- In the event of an emergency or malfunction
- For maintenance work
- For dismantling



## **Risk of injury from escaping compressed air!**

**Never remove any parts of the dryer, or manipulate the same in any way, as long as the unit is pressurised! Suddenly escaping compressed air might cause serious injuries.**

**Prior to any work, release all pressure from the unit.**



## **Caution!**

**Risk of damage to the dryer, if it is switched off during the expansion or drying phase.**

**During these phases, the pressure in the regenerating vessel is released to ambient pressure: If the main valve is opened, as the dryer is switched off, there is a sudden pressure build-up in the vessel. This might result in**

- damage to the drying agent, and
- excessive abrasion, with negative impact on the regeneration capacity.

**Before switching off the dryer, wait until it has reached the pressure build-up phase or is in standby mode (before switchover).**

## **Note:**

**If the unit is equipped with a compressor synchronisation system, first switch off the compressor and then wait until the dryer has reached the standby phase before switching it off with the ON/OFF switch.**

**This ensures that the regeneration cycle is completed, and that the pressure in both vessels is at the same level.**

**As soon as the dryer is switched on again, the programme continues the cycle from the point at which it has been stopped.**

## Emergency shutdown

---

To emergency shut-down the dryer heed to the following instructions:

- ▶ Close shut off valves upstream and downstream of the dryer (if applicable)
- ▶ Disconnect the electrical power supply (i.e. by switching the On/Off switch to **0**).
- The dryer is now off-line.
- ▶ If applicable, depressurise the dryer now.

Before re-commissioning of the dryer ensure that the emergency situation has been solved and that the dryer is not damaged.

Never commission a damaged dryer!

## Depressurising and shutting down the dryer

---

### Close compressed air feed line

- ▶ Close the compressed air inlet valve (provided by the operator).

### Disconnect voltage supply

- ▶ Switch off the dryer by setting the ON/OFF switch to position **0**.

### Disconnect dryer from compressed air system

- ▶ Close the compressed air outlet valve installed by the owner.
- ▶ If available, open bypass line.

### Depressurise dryer

- ▶ Depressurise dryer, e.g. by opening the manual drain at the downstream filter.

## If work is to be carried out on the electrical system

---

- ▶ Depressurise and shut down the dryer, following the instructions in the above chapter.



### **Risk of injury due to voltage-carrying parts!**

**The electrical supply cable and external power lines are live even after the dryer is switched off and, in the event of body contact, may cause serious injury! Before carrying out any work on the electrical system, the electrical supply cable and all external power lines must be made voltage-free!**

- ▶ **Make the electrical supply cable to the dryer voltage-free.**  
Secure the electrical supply cable to the dryer against switch-on.

## Restart

Depending on the fittings installed by the operator and the actual pressure conditions, the unit might have to be restarted at operating pressure. The following general rules apply:

When switched off, the dryer is open in main flow direction. With the optional *start-up device*, the set minimum pressure must however be reached prior to restart.

A return flow is only possible in connection with the optional *regeneration gas return* (and provided that the pressure outlet valve is open).

If the dryer is equipped with a dewpoint-sensing control system, it is depressurised gradually, according to the read measuring current.

### If compressed air system and dryer have remained at operating pressure

- ▶ Ensure that the compressed air inlet valve (provided by the operator) is open.
- ▶ Set ON/OFF switch to **I**. The programme continues the cycle from the point at which it was interrupted.



#### Slowly open compressed air outlet valve!

**Avoid a sudden drop in pressure in any circumstance! If pressure drops too fast, this may cause damage to the dryer. Therefore, the compressed air outlet valve must always be opened quite slowly!**

- ▶ Slowly open the compressed air outlet valve installed by the owner. The pressure should not drop below the operating pressure (if poss.). If necessary, keep the compressed air outlet valve in a slightly open position until the compressed air system downstream of the dryer has filled up completely; only then should the valve be opened fully.
- ▶ If available, block off bypass line.

The dryer is now in operation again and operates fully automatically.

### If compressed air system and dryer have not remained at operating pressure

- ▶ If disconnected, reconnect the voltage supply of the dryer.
- ▶ Pressurise and switch on the dryer as described in the section *Open compressed air supply and switch on dryer* on page 31.

The dryer is now in operation again and operates fully automatically.

# Maintenance and repair of the dryer

In order to allow maintenance work on the dryer to be carried out efficiently and without danger for maintenance personnel, you should comply with the following instructions.

## Notes on maintenance



### Danger!

**There is a very considerable risk of personal injury, when carrying out work on the activated and pressurised dryer.**



**Before commencing any maintenance tasks always shut down the dryer as described on page 36, !**



### Warning!

**Maintenance tasks may be carried out only by authorized and qualified specialist personnel, and only with the plant in a switched off and depressurised condition.**

### Note:

**In order to ensure perfect maintenance and reliable operation we recommend that you conclude a maintenance contract.**

**When exchange or replacement parts are ordered, always state the dryer type and the build no. of the dryer. These data are found on the type plate.**

- Carry out all maintenance work only when the plant has been shut down and depressurised!
- Bolt connections must be undone with care! Note ram pressure values! Otherwise emerging media may cause personal injury.
- Do not modify the factory settings of the control system in any way without prior consultation with the manufacturer.
- Never carry out any manipulations on a hollow profile vessel or modify the same in any way!
- Following maintenance work, always check all flange and bolt connections for leakage and secure seating.
- Never use pipes and fittings as steps or holding points! The components might fracture, or the distortions which occur may cause internal damage on the dryer. There is a risk of injury by slipping off the components, components breaking off, and expanding compressed air!
- Never leave tools, loose parts or cloths at or on the dryer.
- Only use replacement parts that are suitable for the relevant function and meet the technical requirements stipulated by the manufacturer. This is always the case, if you use original replacement parts only.

## Regular maintenance intervals

### Note:

If a vessel has been depressurised, e.g. after completion of the expansion phase, and the pressure remains above 0 bar, the vessel is pressurised by what is known as ram pressure. This might be due to

- blockage at the muffler(s),
- contamination of the dust sieves,
- spent drying agent.

**To prevent such malfunctions, regularly service the dryer as described below.**

The table provides an overview of the maintenance work to be carried out. The following pages describe some of these tasks. Maintenance work requiring the dryer to be largely disassembled is not described. We recommend to have this work to be performed by authorised specialists.

| Component  | Maintenance task to be carried   | Maintenance interval |           |           |           |          |
|--|--|----------------------|-----------|-----------|-----------|----------|
|  |  | daily                | 12 months | 24 months | 48 months | see page |
| Complete dryer   | Carry out visual and function checks.  | ●                    |           |           |           | 41       |
| Vessel pressure gauge                                      | Check dam pressure. For a dam pressure exceeding 0.3 bar:<br>– Check muffler.<br>– Check dust sieve.<br>– Check drying agent.                  | ●                    |           |           |           | 41       |
| Muffler  | Replace muffler after 1 year of operation and after renewing the dessicant.  |                      | ●         |           | ●         | 41       |
| Fine filter muffler  | Replace element of fine filter muffler after 1 year of operation and after renewing the drying agents.   |                      | ●         |           | ●         | 41       |
| Dew point sensor (with optional dew point sensing-control) | Renew  |                      | ●         |           |           | 43       |
| Pilot valves   | Renew.   |                      | ●         |           |           | 44       |
| Main valves V1/V2  | Renew.   |                      |           | ●         |           | 44       |
| Expansion valves V3/V4                                     | Renew.   |                      |           | ●         |           | 44       |
| Check valves V5/V6   | Renew.   |                      |           | ●         |           | 44       |
| Solenoids  | Renew.   |                      |           | ●         |           | 44       |
| Drying agent   | Renew.   |                      |           |           | ●         | 44       |
| Upstream and downstream filter                             | Please see the enclosed operating instructions for the attached filters. Maintenance work has to be carried out as specified in this document. |                      |           |           |           |          |

When carrying out any maintenance work, comply with the following safety instructions:



**Danger!**

There is a very considerable risk of personal injury, when carrying out work on the activated and pressurised dryer.



Before commencing any maintenance tasks always shut down the dryer as described on page 36, !



**Warning against electrical voltage!**

Only qualified specialist personnel may carry out work on the electrical system!

## Instructions for use of the dongle

If the message **SEr.** is displayed on the display of the Multitronic controller, the dryer is due for servicing. The message appears, flashing every 60 seconds, once the preset number of operating hours (e. g. 8000 oh) has been reached. After maintenance has been carried out, you can use the dongle to reset the counter to 0 and delete the message from the display. A dongle is enclosed with every service kit. Each dongle can only be used once.

- ▶ Switch off the controller. Caution! The electric line is still live. Do not touch live parts!
- ▶ Open the lid to the Multitronic controller. The circuit board is housed underneath it.
- ▶ Slot the dongle into the dongle interface *X9 PC*.
- ▶ Press and hold the reset key *S3*.
- ▶ Switch on the controller. The following appears in the display:

|                  |              |
|------------------|--------------|
| for a short time | <b>0.SET</b> |
| then flashing    | <b>OFF</b>   |

The service counter is then reset to 0.

If the following appears in the display:

|                  |             |
|------------------|-------------|
| for a short time | <b>FAIL</b> |
| then flashing    | <b>OFF</b>  |

this means that the dongle has already been used once and cannot be used again.

- ▶ Switch off the controller again and remove the dongle.
- ▶ Dispose of the unusable dongle and use a new one.



## Daily maintenance tasks

### Carry out visual and function check on the complete dryer

- ▶ Check dryer for external damage or unusual noise generation.
- ▶ Duly eliminate any defects found.

If message **SEr.** is displayed, a routine service must be completed:

- ▶ Contact the service department of the manufacturer.

### Clean dryer

- ▶ Remove any loose dust by means of a dry cloth, and, if required, also by means of a moist and well wrung cloth.
- ▶ Clean the surfaces with a moist well wrung cloth.

### Check dam pressure

If, following depressurisation of a vessel, e.g. after the expansion phase, the overpressure has not decreased to 0 bar, then there is a residual pressure, designated as dam pressure, in the vessel.

- ▶ Check for dam pressure: if the dryer functions correctly, the respective pressure gauge indicates 0 bar. Then there is no dam pressure.

If the dam pressure is greater than 0.3 bar:

- ▶ Depressurise the dryer and shut it down (see page 36).

Dam pressure can be caused by:

a blocked muffler,  
a blocked dust sieve or  
drying agent which is too old.

The respective necessary maintenance measures are described in the following sections.

## Maintenance work to be completed every 12 months

### Renew muffler

The dryer is equipped with a muffler. If the muffler becomes blocked, a dam pressure is generated which in extreme cases may cause the muffler to burst.



#### **Hazard caused by blocked muffler!**

**Blocked mufflers can cause a dangerous overpressure to build up which may cause the mufflers to burst. Flying fragments may cause personal injury and damage to property.**

**Therefore, the mufflers must be replaced every 12 months and after each change of desiccant.**



**Warning against sudden air ejection!**

**During expansion the pressure is released suddenly through the muffler:**

- A loud cracking noise occurs which can injure your hearing.
- Particles carried in the air flow act like bullets and can injure your eyes or skin.

**Always wear eye and ear protection, therefore, when you are in the vicinity of the dryer!**

- ▶ Depressurise the dryer and shut it down (see page 36).
- ▶ Unscrew muffler as shown in the opposite figure.
- ▶ Replace muffler and secure it.

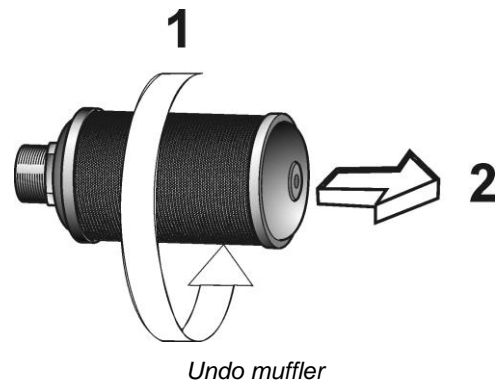

- ▶ Restart dryer (see page 37).

**Replace the element in the fine filter muffler**

- ▶ Depressurise the dryer and shut it down (see page 36).
- ▶ Undo knurled screw on the lid cap and remove cap.
- ▶ Unscrew old filter element. Arrows on the element bottom mark the direction of rotation.

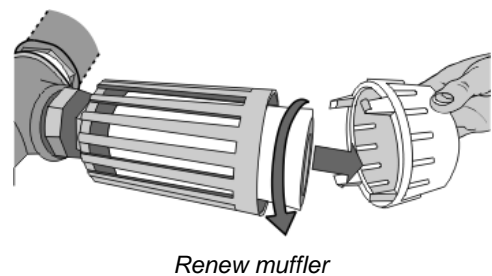

- ▶ Insert new filter element and screw on tightly.
- ▶ Re-engage lid cap at the top section of the housing and fix in position by means of the knurled screw.
- ▶ Restart dryer (see page 37).

## Renew dewpoint sensor

To ensure precision dew point measurement, it is recommended to replace the dew point sensor every year. This period depends however on the actual application and might thus be extended accordingly.

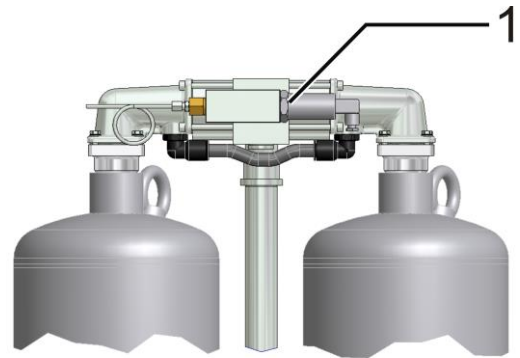

Dewpoint sensor (1)



### Warning!

**The dew point sensor is a sensitive measuring device. It can be damaged if subjected to forceful vibrations or shocks. Therefore, please handle the dew point sensor with great care at all times.**

In order to limit the impact on the dryer operation to a minimum, we recommend that you contact the manufacturer well in advance (for contact details, see page 7) and order a new dewpoint sensor. After receipt of the new pressure dewpoint sensor, replace the sensor as follows:

- ▶ Hold the box of the dewpoint sensor ready.
- ▶ Release pressure from dryer and shut down the unit (see page 36)

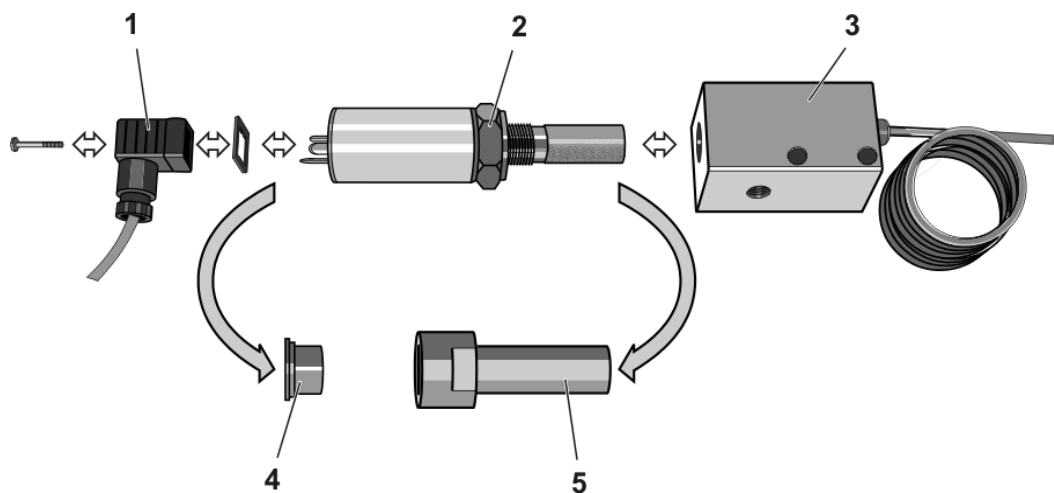

Installing / dismantling pressure dewpoint sensor

- ▶ Loosen the screw at the adapter (1) and disconnect signal cable with the adapter and seal.
- ▶ Remove dewpoint sensor from the sensor cell (3) by turning the nut (2).
- ▶ Take the new dewpoint sensor (2) from the box, remove the protective caps (4, 5) and screw it into the sensor chamber (3).
- ▶ Place seal onto sealing face; connect adapter (1) and secure it by tightening the screw.
- ▶ If no other maintenance work is to be carried out: Restart the dryer (see page 37).

## Notes on further maintenance work

---

### Every 12 months

#### Replacing pilot valves

The pilot valves are part of every service kit and must be replaced every 12 months.

### Every 24 months

#### Replacing inlet valves (V1/V2) and check valves (V5/V6)

The inlet valves (main valves) and the check valves are part of the 24-month service kits. Replace them every 2 years as a precautionary measure.

#### Expansion valves (V3/V4)

In addition to the inlet valves and the check valves, the expansion valves have to be replaced every 24 months as a precautionary measure.

#### Replacing solenoid coils

Solenoid coils come with the 24-month service kits. Replace them every 2 years.

### Every 48 months

In accordance with national regulations, a pressure vessel inspection may be prescribed to be carried out at regular intervals by an independent supervisory office.

For an inspection of the pressure vessels, the drying agent must be removed.

When inspecting the pressure vessels, it is recommended to check the condition of all fittings such as e.g. sieve bottoms and dust sieves, including gaskets. If necessary, these fittings must be cleaned or renewed.

In the event of comprehensive maintenance or repair tasks, contact the manufacturer.

#### Renew drying agent

The service life of the drying agent is usually approx. 3 to 5 years. However, in favourable installation conditions, the change of drying agent may be carried out at a substantially later date. The change interval depends very significantly from the degree of contamination in the compressed air (or the quality of the compressed air upstream filters). Oil, dust, and dirt particles cover the drying agent surface and reduce its effective surface, in part quite irreversibly.

## Identify and eliminate faults

The following table provides information on what designatory abbreviations are to be used for the various components. These designations are also found in the technical documentation.

| Abbreviation  | Component                          |
|---------------|------------------------------------|
| PI            | Pressure gauge                     |
| PDI           | Differential pressure gauge        |
| V1–V2 (Y1–Y2) | Main valves (solenoid valves)      |
| V3–V4 (Y3–Y4) | Expansion valves (solenoid valves) |
| V5–V6         | Check valves                       |

## Summary of faults

There are different fault types. In the case of most electrically caused faults (e.g. short circuit, defective fuse, etc.) the expansion valve closes and the regeneration is interrupted. In the case of some process faults, the dryer will continue to operate for some time. Other faults on the dryer become noticeable e.g. due to unusual noises and ran pressures.

The following table shows who is allowed to remedy a fault: the owner's specialist personnel or the manufacturer's service engineer.

## Table of possible faults

| Fault                                      | Possible cause  | Remedy   | Spec. personnel | Service engineer |
|--|---|--|-----------------|------------------|
| Excessive dam pressure during regeneration | Muffler or filter element of the muffler is contaminated.           | Check mufflers or filter elements for contamination, clean if nec., and poss. renew.             | ●               | ●                |
|  | Expansion valve V3/V4 does not open correctly.                      | Check expansion valve for contamination, if nec. clean/renew.                                    | ●               | ●                |
|  | Dust sieves are contaminated.                                       | Clean or renew dust sieves.  | ●               | ●                |
| Vessel pressure is too low                 | Excessive differential pressure on the upstream filter.             | Check differential pressure on the upstream filter, if. nec. renew filter element.               | ●               |                  |
| No pressure build up                       | The compressed air system upstream of the dryer is not pressurised. | Check whether the compressed air system upstream of the dryer is pressurised. Remove any faults. | ●               |                  |
|  | Solenoid valve Y1/Y2 does not open correctly.                       | Check supply voltage, cable, contacts and solenoid; replace, if necessary.                       | ●               | ●                |
| Excessive compressed air consumption       | Leakage.  | Check condensate trap at the upstream filter; clean, if necessary.                               | ●               | ●                |

| Fault                             | Possible cause  | Remedy   | Spec. personnel | Service engineer |
|-----------------------------------|---|--|-----------------|------------------|
| Dryer does not switch over        | Solenoid valve Y1/Y2 does not open correctly.   | Check supply voltage, cable, contacts and solenoid; replace, if necessary.   | ●               | ●                |
|                                   | Solenoid valve Y1/Y2 cannot be opened properly (audible humming sound or valve flapping).     | Check supply voltage.<br>Check pilot valves; replace, if necessary.  | ●               | ●                |
|                                   | Control board defective.  | Check fuse in supply line and in the switchbox; replace, if necessary.   | ●               | ●                |
|                                   | Power supply interrupted, cable broken.   | Reconnect the unit to the power supply.  | ●               |                  |
|                                   | Compressor might be off.  | Check compressor synchronisation circuit.  |                 |                  |
|                                   | Error in control programme.   | Restart programme.   |                 | ●                |
| No expansion                      | Solenoid valve Y3/Y4 cannot be opened.  | Check supply voltage, cable, contacts and solenoid; replace, if necessary.   | ●               | ●                |
|                                   | Solenoid valve Y3/Y4 cannot be opened properly (audible humming sound or valve flapping).     | Check supply voltage.<br>Check pilot valves; replace, if necessary.<br>Check valve bodies for contamination; clean or replace, if necessary. | ●               | ●                |
| Dryer is continuously bled        | Solenoid valve Y3/Y4 cannot be closed properly (audible humming sound or valve flapping).     | Check supply voltage.<br>Check solenoid and diaphragm; replace, if necessary.  | ●               | ●                |
|                                   | Main valve V1/V2 does not open.   | Check main valve, replace if nec.  | ●               | ●                |
| Dryer is excessively bled         | Solenoid valve Y1/Y2 cannot be closed.  | Check solenoid and diaphragm; replace, if necessary.   | ●               | ●                |
| Pressure dew point is not reached | Operating pressure is too low.  | Increase operating pressure.   | ●               |                  |
|                                   | Compressed air volume flow is too high.   | Reduce compressed air volume flow  | ●               |                  |
|                                   | Compressed air inlet temperature is too high.   | Reduce compressed air inlet temperature or pre-connect a compressed air cooler.  | ●               | ●                |
|                                   | Control board is defective.   | Check control board, if nec. renew.  |                 | ●                |
|                                   | Differential pressure on the upstream filter is too high.                                     | Check differential pressure on the upstream filter, if nec. renew filter element.  | ●               |                  |
|                                   | Condensate trap on the upstream filter does not work.   | Check function of the condensate trap, if nec. clean or renew.   | ●               | ●                |
|                                   | Drying agent is contaminated or too old.  | Check upstream filter for contamination, if nec. renew element.  | ●               |                  |
|                                   |   | Check drying agent for contamination, if nec. renew drying agent.  | ●               | ●                |
| Regeneration gas too low.         | Check function of expansion valve V3/V4 and muffler, if nec. renew muffler or filter element. | ●  | ●               |                  |
|                                   | sensor is defective   | Replace sensor   | ●               | ●                |

## With dewpoint-sensing control (optional)

| Fault code         | Description of fault   | Possible cause  | Remedy   | Specialised personnel | Service technician |
|--------------------|--|---|--|-----------------------|--------------------|
| +20                | Upper measuring range limit exceeded   | Drying capacity exceeded.                             | See instructions for commissioning. If the drying agent is wet, replace it.  | ●                     |                    |
| 999                | Dewpoint sensor defective  | Error in programme.                                   | Restart programme.   |                       | ●                  |
| sens<br>or<br>-999 | Sensor not powered, or cable or sensor defective                             | Sensor defective or irreversibly contaminated.        | Replace sensor.  | ●                     | ●                  |
| SEr                | Sensor, sensor cable or sensor adapter defective                             | Sensor not powered, or cable or sensor defective      | Visual inspection; check power supply (24 V to terminals 4 and 6). Replace defective component(s).   | ●                     | ●                  |
|                    | Display for service interval. Regular maintenance tasks must be carried out. | The display appears after every 8000 operating hours. | Inform the manufacturer's service staff and order the appropriate service kit. The package includes a dongle with which you can reset the operating hours counter after maintenance has been carried out. For instructions on how to use the dongle see the enclosed information sheet (in the service kit). | ●                     | ●                  |

# Index

## A

|                         |    |
|-------------------------|----|
| Abbreviation            |    |
| Components              | 45 |
| Address, manufacturer   | 7  |
| Adsorption, explanation | 18 |
| air ejection            |    |
| hazard                  | 11 |
| Air ejection, sudden    | 9  |

## B

|                    |        |
|--------------------|--------|
| Bolt connections   | 23     |
| Build no.          | 38, 52 |
| <i>Bypass line</i> | 23     |

## C

|                                       |        |
|---------------------------------------|--------|
| Changing cycle mode                   |        |
| explanation                           | 32     |
| Check valves                          |        |
| maintenance interval                  | 39     |
| Components                            | 45     |
| Compressed air                        | 12, 18 |
| Compressor synchronisation            |        |
| option                                | 20     |
| compressor synchronisation controller | 20     |
| Compressor synchronisation line       |        |
| installation                          | 25     |
| Condensate trap                       |        |
| maintenance interval                  | 39     |
| Connection lines                      | 23     |
| Connector                             |        |
| electrical                            | 24     |
| Control                               |        |
| dewpoint-sensing                      | 21     |
| Control cabinet                       | 17     |
| Control system                        |        |
| signalling contacts                   | 20     |
| Conversions                           | 9      |
| Cycle                                 |        |
| fixed                                 | 21     |
| variable                              | 21     |
| Cycle mode change                     |        |
| explanation                           | 32     |

## D

|                             |        |
|-----------------------------|--------|
| Danger notes                |        |
| Danger!                     | 8      |
| Danger warning, maintenance | 38, 40 |
| Date of manufacture         | 4      |

|                          |    |
|--------------------------|----|
| Dehumidification         |    |
| explanation              | 19 |
| Dew point sensor         |    |
| maintenance interval     | 39 |
| Dewpoint-sensing control | 21 |
| Digital display          |    |
| explanation              | 28 |
| Documentation, technical | 50 |
| Dongle                   |    |
| use                      | 40 |
| Dryer                    |    |
| maintenance interval     | 39 |
| drying agent             |    |
| service life             | 44 |
| Drying agent             |    |
| charging                 | 21 |
| storage                  | 16 |
| drying agents            |    |
| handling                 | 10 |
| dust generation          | 10 |
| dust mask                | 10 |

## E

|                            |    |
|----------------------------|----|
| Ear protection             | 30 |
| electrical voltage, hazard | 11 |
| Example for installation   | 23 |
| Expansion, explanation     | 19 |

## F

|                 |    |
|-----------------|----|
| Fabrication no. | 4  |
| Fixed cycle     | 21 |

## H

|              |    |
|--------------|----|
| hazard areas | 11 |
|--------------|----|

## I

|                                 |    |
|---------------------------------|----|
| Installation area               | 14 |
| Installation example            | 23 |
| Installation site, requirements | 14 |

## L

|                     |    |
|---------------------|----|
| LEDs                |    |
| explanation         | 28 |
| lifting gear        | 13 |
| Limits, permissible | 30 |

## M

|                            |   |
|----------------------------|---|
| Machine damage, prevention | 9 |
|----------------------------|---|



|                                   |        |
|-----------------------------------|--------|
| Machine passport .....            | 4      |
| main voltage .....                | 51     |
| Maintenance                       |        |
| dam pressure.....                 | 41     |
| drying agent.....                 | 44     |
| Muffler.....                      | 41     |
| sensor.....                       | 43     |
| Maintenance contract .....        | 38     |
| Maintenance, danger warnings..... | 38, 40 |
| Misuse .....                      | 12     |
| Misuse, suspected.....            | 12     |
| Modifications on the dryer .....  | 9      |
| Muffler                           |        |
| maintenance interval .....        | 39     |
| <hr/>                             |        |
| <b>N</b>                          |        |
| <b>Noise level</b> .....          | 51     |
| Notes                             |        |
| safe, efficient handling.....     | 8      |
| <hr/>                             |        |
| <b>O</b>                          |        |
| On/Off switch                     |        |
| explanation .....                 | 27     |
| On/Off-Swit.....                  | 17     |
| Operating instructions.....       | 7      |
| safe place .....                  | 8      |
| safety notes .....                | 9      |
| target group .....                | 8      |
| <b>Operating overpressure</b>     |        |
| <b>minimum, maximum</b> .....     | 51     |
| Operating pressure.....           | 31     |
| permissible .....                 | 4      |
| safety device.....                | 22     |
| Operating signalling contact      |        |
| installation.....                 | 25     |
| Operation signalling              |        |
| contact.....                      | 20     |
| Original replacement parts .....  | 38     |
| overpressure, hazard.....         | 11     |
| <hr/>                             |        |
| <b>P</b>                          |        |
| Packaging.....                    | 13     |
| Personnel qualification .....     | 9, 40  |
| Pressure build-up                 |        |
| explanation .....                 | 19     |
| sudden.....                       | 31     |
| Pressure Conditions .....         | 37     |
| Pressure vessel.....              | 38     |

|                        |    |
|------------------------|----|
| Programme              |    |
| sequence, steps .....  | 55 |
| Protection class ..... | 51 |
| <hr/>                  |    |

**R**

|   |    |
|---|----|
| Regeneration, explanation.....            | 18 |
| Regulations for accident prevention ..... | 13 |
| Replacement parts .....                   | 38 |
| <hr/>                                     |    |

**S**

|                                |        |
|--------------------------------|--------|
| Safety notes.....              | 9      |
| general.....                   | 9      |
| Warning! .....                 | 8      |
| Safety valves .....            | 22, 26 |
| Shutdown valves .....          | 23     |
| Shutting down.....             | 36     |
| Signalling lines               |        |
| external.....                  | 25     |
| skid risk.....                 | 11     |
| Specialist personnel .....     | 8, 22  |
| Standard equipment .....       | 7      |
| Start-up device .....          | 20     |
| Start-up, requirements.....    | 26     |
| Storage room                   |        |
| requirements.....              | 16     |
| Supply cable, electrical ..... | 24     |
| Supply lines .....             | 22     |
| symbols, explanation .....     | 11     |
| <hr/>                          |        |

**T**

|                        |    |
|------------------------|----|
| Target group.....      | 8  |
| Transport damage ..... | 13 |
| transport lugs.....    | 15 |
| Type plate.....        | 10 |
| <hr/>                  |    |

**U**

|                     |    |
|---------------------|----|
| Use, intended ..... | 12 |
| Use, safe .....     | 8  |
| <hr/>               |    |

**V**

|                           |    |
|---------------------------|----|
| Variable cycle .....      | 21 |
| Vessel pressure gauge     |    |
| maintenance interval..... | 39 |
| vibration dampers .....   | 15 |
| Visual inspection.....    | 41 |
| Voltage                   |    |
| electrical .....          | 24 |

---

## Annex with technical documentation

This annex comprises the following information and technical documentation:

Technical data

Replacement and wear parts list

Logic control diagram

Flow diagram

Dimensional drawing

## Technical data

### Operating Range

|                                  |   |
|----------------------------------|---|
| Site Selection                   | frost-free indoor installation in a non-hazardous environment |
| Ambient temperature              | 1,5 to 50 °C (34,7 to 122 °F)                                 |
| Compressed air inlet temperature | 25 to 50 °C (68 to 122 °F)                                    |
| max. operating overpressure      | 16 bar <sub>e</sub>   |
| operating overpressure, minimal  | 5 bar <sub>e</sub>  |
| Medium                           | Compressed air and gaseous nitrogen                           |
| Fluid group                      | 2   |

### Electrical connection

|   |                             |
|---|-----------------------------|
| Main voltage, standard  | 230 V, 50-60 Hz             |
| Alternative voltage   | 115 V, 50-60 Hz and 24 V DC |
| Protection class  | IP65                        |
| <b>Please heed to the type plate and enclosed wiring diagram!</b> |                             |

### Performance data

| Model   | Volumetric flow in m <sup>3</sup> /h | Nominal pipe | Upstream filter | Downstream filter | Nominal Pressure in bar(e) | Nominal temperature in °C |
|---------|--------------------------------------|--------------|-----------------|-------------------|----------------------------|---------------------------|
| K-MT 10 | 105                                  | 1            | GL9XLD          | GL9ZLDH           | 16                         | 50                        |
| K-MT 15 | 145                                  | 1            | GL9XLD          | GL9ZLDH           | 16                         | 50                        |
| K-MT 20 | 200                                  | 1            | GL9XLD          | GL9ZLDH           | 16                         | 50                        |
| K-MT 25 | 255                                  | 1 1/2        | GL11XLD         | GL11ZLDH          | 16                         | 50                        |
| K-MT 35 | 350                                  | 1 1/2        | GL11XLD         | GL11ZLDH          | 16                         | 50                        |
| K-MT 45 | 420                                  | 1 1/2        | GL12XLD         | GL12ZLDH          | 16                         | 50                        |
| K-MT 60 | 620                                  | 2            | GL13XLD         | GL13ZLDH          | 16                         | 50                        |
| K-MT 75 | 750                                  | 2            | GL13XLD         | GL13ZLDH          | 16                         | 50                        |
| K-MT 95 | 940                                  | 2 1/2        | GL14XLD         | GL14ZLDH          | 16                         | 50                        |

<sup>1</sup> m<sup>3</sup>/h relating to 1 bara and 20 °C at the compressor suction capacity., subsequently compressed to 7 bare and 35 °C inlet temperature to the dryer at 100 % relative humidity for pressure dewpoints of von -25 und -40 °C.

<sup>2</sup> in accordance with DIN ISO 228 (BSP-P).

### Noise emission

|                                     |               |
|-------------------------------------|---------------|
| Noise level: +3 dB (A) <sup>1</sup> | 65 – 95 dB(A) |
|-------------------------------------|---------------|

relative to free field measurement, 1 m surr. field

### Drying agent

|          |                       |
|----------|-----------------------|
| Vessel 1 | 100 % molecular sieve |
| Vessel 2 | 100 % molecular sieve |

### Dimensions

Please heed to the dimensional drawings and the according table containing dimensions and weight on page 58.

## Replacement and wear parts list

**Note:**

When exchange or replacement parts are ordered, always state the dryer type and the build no. of the dryer. These data are found on the type plate.

### Service kits 12 and 36 months

| For model          | Mains voltage | Order-ID.       | Scope of delivery                                    |
|--------------------|---------------|-----------------|--|
| K-MT 10 to K-MT 20 | 115V, 230V    | SKK10-K20/D2/12 | Reset-module, muffler, filter elements, pilot-valves |
| K-MT 25            | 115V, 230V    | SKK25/D2/12     | Reset-module, muffler, filter elements, pilot-valves |
| K-MT 35            | 115V, 230V    | SKK35/D2/12     | Reset-module, muffler, filter elements, pilot-valves |
| K-MT 45            | 115V, 230V    | SKK45/D2/12     | Reset-module, muffler, filter elements, pilot-valves |
| K-MT 60 to K-MT 75 | 115V, 230V    | SKK60-K75/D2/12 | Reset-module, muffler, filter elements, pilot-valves |
| K-MT 95            | 115V, 230V    | SKK95/D2/12     | Reset-module, muffler, filter elements, pilot-valves |

## Service kits 24 and 36 months

| For model          | Mains voltage | Order-ID.           | Scope of delivery  |
|--------------------|---------------|---------------------|--|
| K-MT 10 to K-MT 20 | 115V          | SKK10-K20/D2/24/115 | Reset-module, muffler, filter elements, inlet- expansion- and check valves, solenoid |
|                    | 230V          | SKK10-K20/D2/24     |  |
| K-MT 25            | 115V          | SKK25/D2/24/115     | Reset-module, muffler, filter elements, inlet- expansion- and check valves, solenoid |
|                    | 230V          | SKK25/D2/24         |  |
| K-MT 35            | 115V          | SKK35/D2/24/115     | Reset-module, muffler, filter elements, inlet- expansion- and check valves, solenoid |
|                    | 230V          | SKK35/D2/24         |  |
| K-MT 45            | 115V          | SKK45/D2/24/115     | Reset-module, muffler, filter elements, inlet- expansion- and check valves, solenoid |
|                    | 230V          | SKK45/D2/24         |  |
| K-MT 60 to K-MT 75 | 115V          | SKK60-K75/D2/24/115 | Reset-module, muffler, filter elements, inlet- expansion- and check valves, solenoid |
|                    | 230V          | SKK60-K75/D2/24     |  |
| K-MT 95            | 115V          | SKK95/D2/24/115     | Reset-module, muffler, filter elements, inlet- expansion- and check valves, solenoid |
|                    | 230V          | SKK95/D2/24         |  |

## Additional spare parts

| Order no.           | Maintenance interval | Quantity | Scope of delivery           |
|---------------------|----------------------|----------|-----------------------------|
| ZHM100/450          | 12 months            | 1        | Dewpoint sensor             |
| LS5/ZR              | 12 months            | 1        | Element fine filter muffler |
| RK-MANO.063SR0219-1 | When necessary       | 1        | Vessel pressure gauge       |

## Desiccant packs

| Typ     | Order-ID.    | Content  |
|---------|--------------|--|
| K-MT 10 | K-MT10DESMIX | Both chambers have to be filled completely with adequate desiccant packets acc. to the maintenance instructions. |
| K-MT 15 | K-MT15DESMIX |  |
| K-MT 20 | K-MT20DESMIX |  |
| K-MT 25 | K-MT25DESMIX |  |
| K-MT 35 | K-MT35DESMIX |  |
| K-MT 45 | K-MT60DESMIX |  |
| K-MT 60 |              |  |
| K-MT 75 | K-MT75DESMIX |  |
| K-MT 95 | K-MT95DESMIX |  |

# Flow diagram

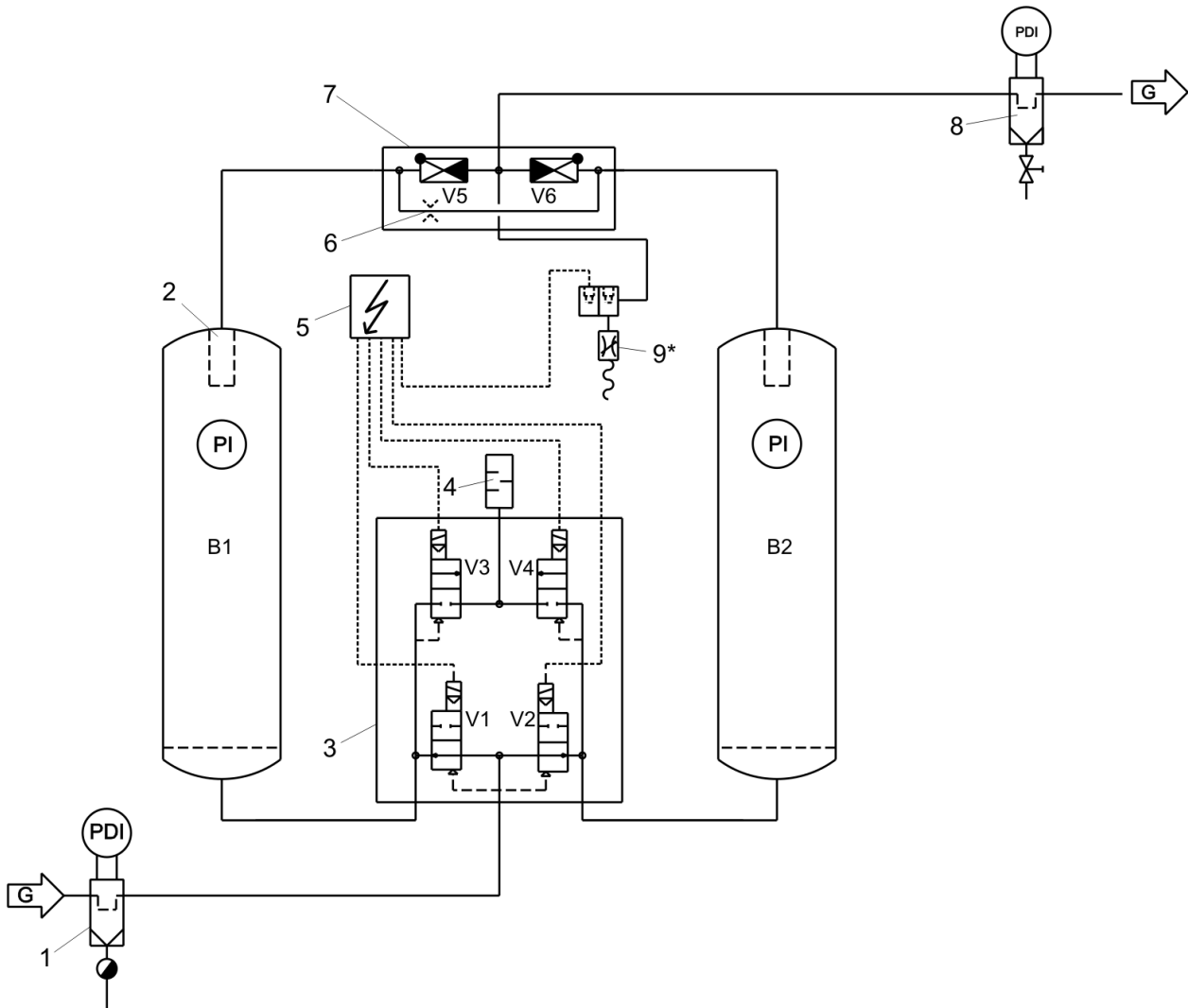

| Pos.       | Designation                    |
|------------|--------------------------------|
| 1          | Upstream filter                |
| 2          | Dust sieve                     |
| 3          | Solenoid valve block V1–V4     |
| 4          | Muffler                        |
| 5          | Control system                 |
| 6          | Regeneration gas orifice plate |
| 7          | Check valve block V5–V6        |
| 8          | Downstream filter              |
| * Options: |                                |
| 9          | Dewpoint-sensing unit          |

# Logic control diagram

## Adsorption in B1 and regeneration in B2

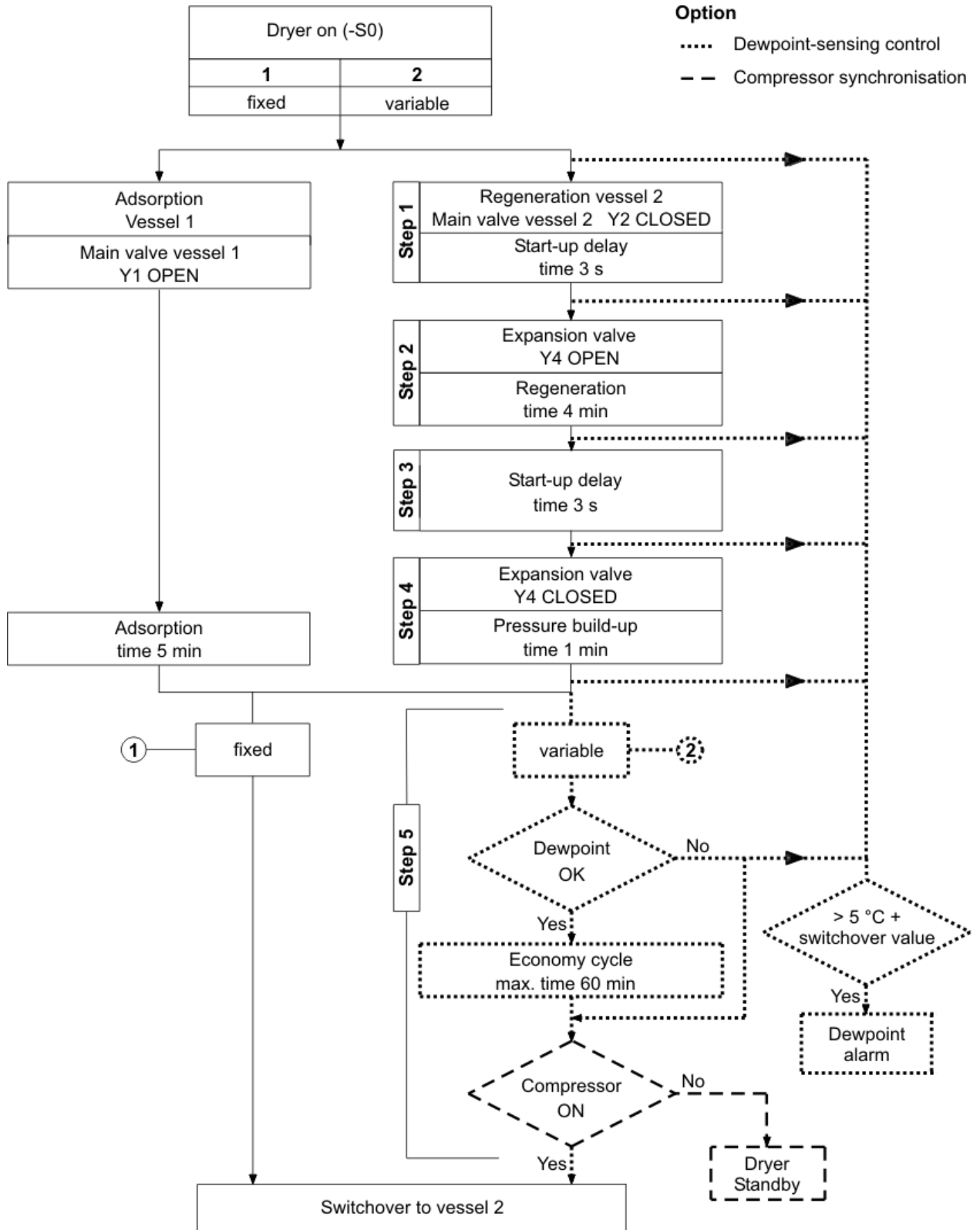

## Regeneration in B1 and adsorption in B2

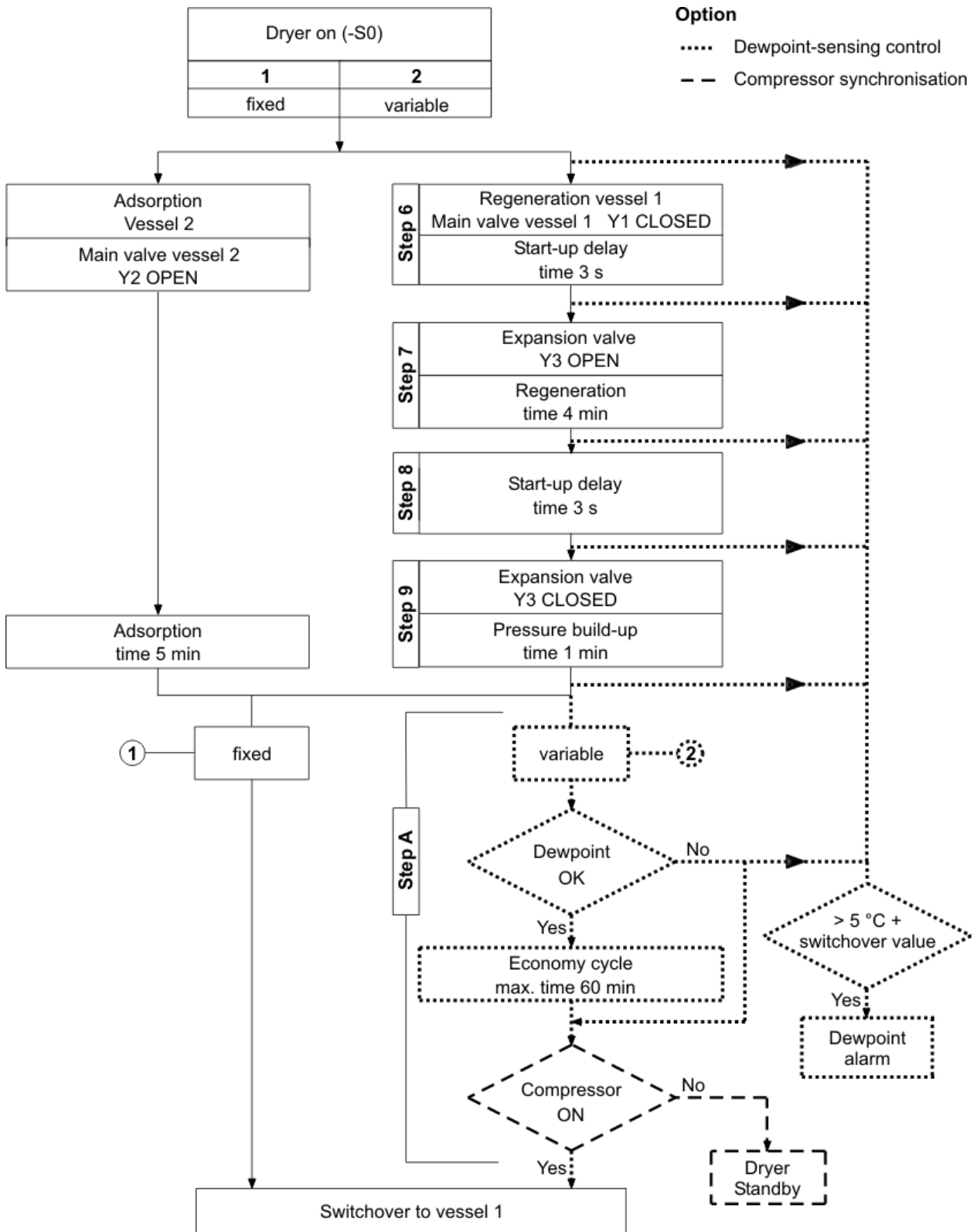



## Dimensional drawing

### K-MT 10 & K-MT 15

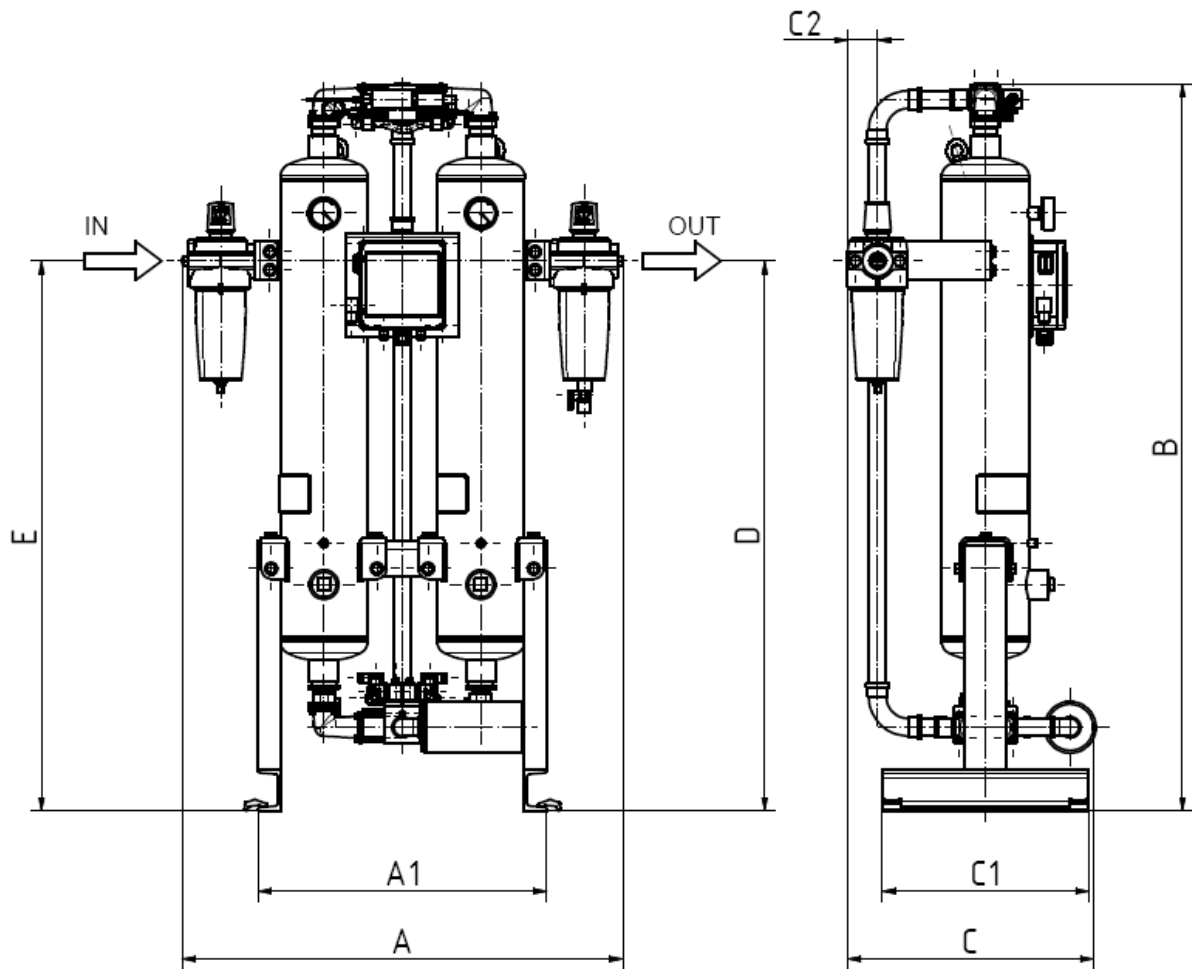

**K-MT 20 – K-MT 95**

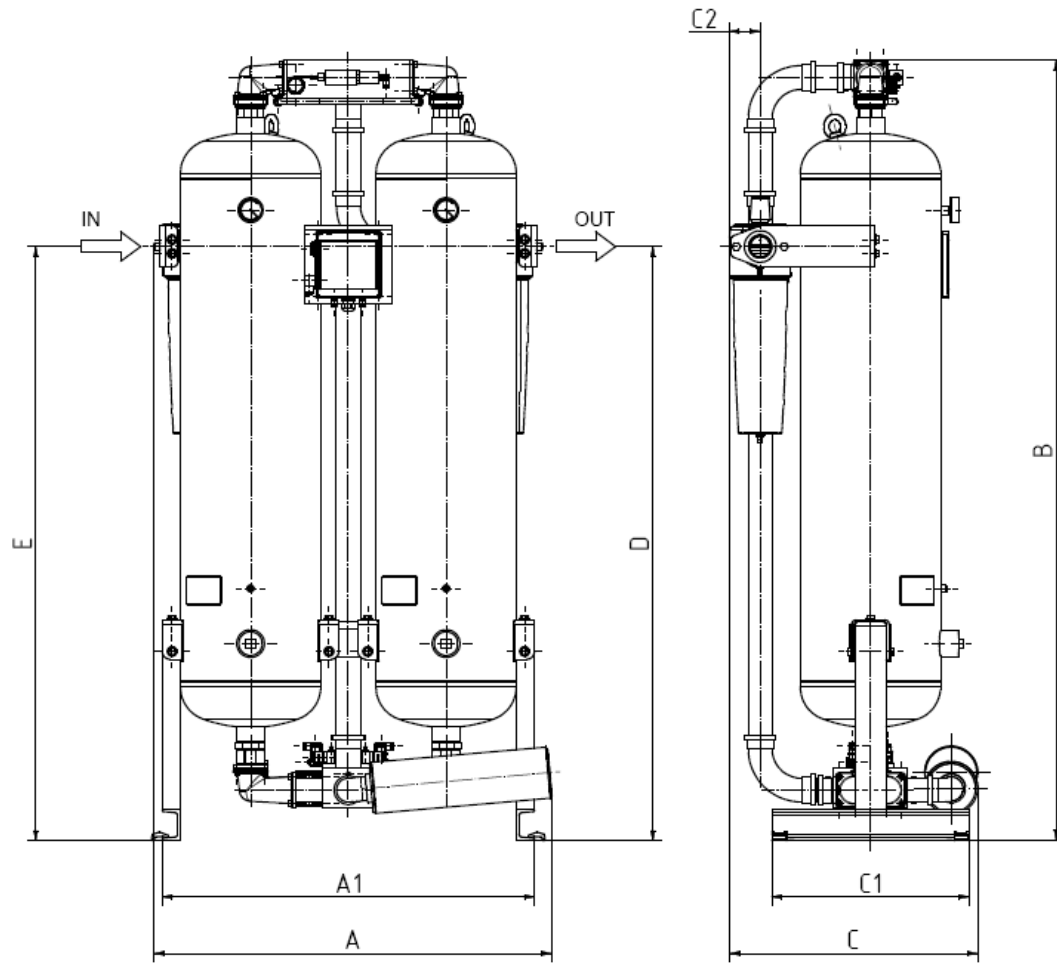

| Type    | Connection | Dimensions [mm] |      |      |     |     |    |      |      | weight [kg] |
|---------|------------|-----------------|------|------|-----|-----|----|------|------|-------------|
|         |            | A               | A1   | B    | C   | C1  | C2 | D    | E    |             |
| K-MT 10 | G 1        | 870             | 570  | 1420 | 490 | 400 | 60 | 1070 | 1070 | 120         |
| K-MT 15 | G 1        | 870             | 570  | 1750 | 490 | 400 | 60 | 1320 | 1320 | 142         |
| K-MT 20 | G 1        | 670             | 630  | 1530 | 490 | 400 | 60 | 1160 | 1160 | 143         |
| K-MT 25 | G 1½       | 670             | 630  | 1760 | 530 | 400 | 60 | 1320 | 1320 | 173         |
| K-MT 35 | G 1½       | 830             | 790  | 1810 | 585 | 400 | 60 | 1320 | 1320 | 210         |
| K-MT 45 | G 1½       | 860             | 820  | 1820 | 605 | 400 | 80 | 1320 | 1320 | 249         |
| K-MT 60 | G 2        | 910             | 860  | 1870 | 635 | 500 | 80 | 1320 | 1320 | 277         |
| K-MT 75 | G 2        | 1020            | 950  | 2000 | 640 | 500 | 80 | 1515 | 1515 | 408         |
| K-MT 95 | G 2½       | 1050            | 1000 | 2020 | 670 | 500 | 80 | 1515 | 1515 | 510         |