

EFFICIENCY
AND ECONOMY

COMBINED



ANTARES

HYBRID COMPRESSED AIR DRYER

Parker Hiross Antares high efficiency tandem technology refrigeration and adsorption dryer.

Innovative family of compressed air hybrid dryers with optional add-ons. Combining low energy consumption, with unique adaptability allowing Antares to deliver a cost-effective solution across a wide range of industrial applications.

EXCLUSIVE HYBRID TANDEM TECHNOLOGY

The unique combination of refrigeration and adsorption drying techniques delivers a reduction in energy consumption of up to 60% compared with traditional heatless desiccant dryers, resulting in approximately 15% more clean, dry air downstream.

› Energy saving technology

A standard feature on all models, it automatically adapts dryer operation to the ambient inlet conditions and compressed air demand, ensuring optimum energy consumption and full utilisation of the desiccant material

› ISO12500 validated filters

Three integrated high performance filters ensure high process safety; located prior to the refrigeration circuit, and pre and post adsorption stage.

› Integral condensate drain

Ensuring higher system efficiency as no compressed air is wasted. External capacitive drain available as optional upgrade for models ATT025-090

› Optional extras

By-pass for seasonal operation

(Models ATT060-340)

Enabling the Antares to save additional energy by meeting dewpoints above zero in summer using only the fridge section, and below zero in winter using the tandem configuration.

7" colour touchscreen display

(Models ATT140-340)

Keeping you fully informed and in control of dryer operations.

Ambient temperature probe

(Models ATT060-340)

For dewpoint suppression and/or activation of seasonal by-pass.

ModBus communication interface

Providing optimum system reliability and ease of use.

Flow Rates

Model	Order-No.	Port Connection BSPP-F	Flow Rate		Effective Average. Absorbed Power ² kW	Purge Air Equivalent Absorbed Power ³ kW
			Inlet m ³ /min	Outlet m ³ /min		
ATT 025	ATT025-A23015016TI	1"	2.5	2.4	0.94	0.42
ATT 040	ATT040-A23015016TI	1"	4.0	3.9	1.30	0.68
ATT 060	ATT060-A23015012TI	1 1/2"	6.0	5.8	1.27	1.02
ATT 090	ATT090-A23015012TI	1 1/2"	9.0	8.7	1.94	1.53
ATT 140	ATT140-A40035012EI	2"	14	13.6	2.01	2.37
ATT 260	ATT260-A40035012EI	2 1/2"	26	25.2	4.02	4.41
ATT 340	ATT340-A40035012EI	2 1/2"	34	32.9	5.17	5.76

¹ Referring to 1 bar(a) and 20 °C at compressor suction capacity. Subsequently compressed to 7 bar g at 35 °C inlet to the dryer, at 100 % relative humidity, 25 °C ambient, for -40 °C pressure dew-point. Outlet flow is the average net flow following subtraction of the average purge-air flow.

² Calculated throughout the entire cycle period - includes total refrigeration-circuit and desiccant heater absorbed power.

³ Purge-air flow throughout the entire cycle period, evaluated as an air compressor absorbed power at the rate of 5.5 kW/m³/min.

Correction Factors for ATT Model Selection

Inlet Temperature (°C)	30	35	40	45	50	55	60	65
Correction Factor	1.22	1	0.81	0.69	0.59	0.52	0.46	0.4

Working Pressure (bar g) ¹	4	5	6	7	8	9	10	11	12	13	14	15	16
Correction Factor	0.62	0.75	0.87	1	1.08	1.2	1.28	1.34	1.4	1.45	1.5	1.54	1.6

Ambient Temperature (°C)	20	25	30	35	40	45	50
Correction Factor ATT025-040	1.05	1	0.94	0.88	0.81	0.75	0.68
Correction Factor ATT060-340	1.06	1	0.95	0.90	0.83	0.77	0.72

Note:

The above correction factors are approximative; please refer always to the software selection program for a precise selection.

¹ Model ATT025 - ATT040 max 16 bar g
Model ATT060 - ATT340 max 12 bar g

Example: Air flow 500m³/hour, operating pressure 8 bar g, 40°C inlet temperature, 30°C ambient temperature at -40 °C pdp

- Find the correction factor in the table above: 8 bar_g = 1.08 ; 40 °C inlet = 0.81 ; 30 °C ambient = 0.95.
- Calculate the required capacity: 1.08 x 0.81 x 0.95 = 0.83; 500/0.83 = 602 m³/h ; 602 / 60 = 10 m³/min.
- Select the model which corresponds to the calculated capacity. It is acceptable to overload a model by 10 %:
 - If the requested air flow is intended to be the inlet flow to the dryer, select model ATT090. This model can nominally treat 9.0m³/min inlet flow (loading it with 10m³/min is acceptable approx. 10 % more).
 - If the requested air flow is intended to be the treated air flow at the output of the dryer, than select a larger model ATT140. Model ATT090 can deliver 8.7m³/min at the output, so requiring 10m³/min would be almost 15 % more than its rated performance. In this case the next model must be selected.
- If the requirement is for a different dew-point, the selection procedure does not alter. The required pressure dew-point does not affect the model selection. It impacts only on the total power used by the selected model.

Corection Factors for Alternative pdp and/or at Partial Load

Pressure Dew-point (°C)	Refrig. only	+3	0	-10	-20	-40	-70
Correction Factor	0.39	0.88	0.89	0.90	0.92	1	1.31

Partial Load	25 %	50 %	75 %	100 %
Correction Factor	0.66	0.82	0.94	1
Correction Factor Refrigeration-circuit only ¹	0.52	0.76	0.90	1

¹ ATT140-260-340 only

Example: ATT140 working at -20°C pdp and loaded with 50 % of its nominal capacity

- Find the correction factor in the table above: -20 °C pdp = 0.92 ; 50 % load = 0.82.
- The total power at nominal conditions consumed by model ATT140 (see performance table) is: 2.01 + 2.37= 4.38kW.
- Apply the correction factor. The total power consumed at the new conditions is: 4.38 x 0.92 x 0.82 = 3.30kW.

Example: ATT140 with seasonal "By-pass Option" (Refrigeration-circuit only active), unit loaded at 50%

- Find the correction factor in the table above: Refrigeration-circuit only = 0.39 ; 50 % load with refrigeration-circuit only = 0.76.
- Apply the correction factor to the total power consumed by an ATT140. The new value is: 4.38 x 0.39 x 0.76 = 1.3kW.

Technical Data

Model	Min Working Pressure	Max Working Pressure	Min Inlet Temperature	Max Inlet Temperature	Min Ambient Temperature	Max Ambient Temperature	Electrical Supply
ATT 025	2 bar g	16 bar g	5 °C	65 °C	5 °C	50 °C	230V, 1-phase, 50Hz
ATT 040	2 bar g	16 bar g	5 °C	65 °C	5 °C	50 °C	230V, 1-phase, 50Hz
ATT 060	2 bar g	12 bar g	5 °C	65 °C	5 °C	50 °C	230V, 1-phase, 50Hz
ATT 090	2 bar g	12 bar g	5 °C	65 °C	5 °C	50 °C	230V, 1-phase, 50Hz or 400V, 3-phase, 50Hz
ATT 140	2 bar g	12 bar g	5 °C	65 °C	5 °C	50 °C	400V, 3-phase, 50Hz
ATT 260	4 bar g	12 bar g	5 °C	65 °C	5 °C	50 °C	400V, 3-phase, 50Hz
ATT 340	4 bar g	12 bar g	5 °C	65 °C	5 °C	50 °C	400V, 3-phase, 50Hz

Materials of Construction

Filters	See product-specification regarding GL PLUS filter ref: ZL and XL
Heat Exchanger Fridge Section	Stainless Steel plate-heat exchanger on ATT025-040 All-in-one „T-Smart Pack“ Aluminium heat exchanger on ATT060-340
Refrigerant Fluid	R134a in ATT025-040; R407C in ATT060-340
Pressure Vessels	Aluminium for ATT025-040; Carbon Steel for ATT060-340
Valve Blocks	ATT025-140: Brass valve, Aluminium blocks, ATT260-340: 3-way valve galvanised steel, ball AISI 304, plastic check valves
Filling of Desiccant Section	Water-resistant Silica Gel
Protection Class	IP44

Air Quality Class in Accordance with ISO 8573-1:2010

Particulate	Class 2
Humidity (gaseous)	From Class 4 to Class 1 (depending upon dew-point setting)
Total Oil Contamination	Class 2

Product Key

Series	Inlet Flow Rate x10 (m³/min)	Condenser	Electrical Voltage, Phase, Frequency	Max Operating Pressure (bar g)	Condensate Drain Type	By-pass Winter/Summer (Optional)	Touch screen (Optional)	Ambient Temperature Probe (Optional)	ModBus Interface (Optional)
ATT	025 to 040	A	230150	16	TI or EX	-	-	-	-
ATT	060 to 090	A or W	230150	12	TI or EX	TB	-	TP	C
ATT	140 to 340	A or W	400350	12	EI	TB	TS	TP	C

Product Key Examples

ATT	040	A	230150	16	TI				
ATT model for 4 m³/min inlet, air cooled, 230 V, 1-phase, 50Hz power supply, max 16 bar g operating pressure, equipped with integral timed condensate drain.									
ATT	040	A	230150	16	EX				
ATT model for 4 m³/min inlet, air cooled, 230 V, 1-phase, 50Hz power supply, max 16 bar g operating pressure, equipped with external electronic capacitive condensate drain.									
ATT	260	A	400350	12	EI		TS		
ATT model for 26 m³/min inlet, air cooled, 400 V, 3-phase, 50Hz power supply, max 12 bar g operating pressure, equipped with integral electronic capacitive condensate drain and 7" touch screen display.									
ATT	140	A	400350	12	EI	TB	TS		
ATT model for 14 m³/min inlet, air cooled, 400 V, 3-phase, 50Hz power supply, max 12 bar g operating pressure, equipped with integral electronic capacitive condensate drain, seasonal "By-Pass" and 7" touch screen display.									
ATT	340	A	400350	12	EI		TS	TP	C
ATT model for 34 m³/min inlet, air cooled, 400 V, 3-phase, 50Hz power supply, max 12 bar g operating pressure, equipped with capacitive condensate drain, 7" touch screen display, ambient temperature probe and ModBus communication interface.									

Weights & Dimensions

Model	Port Connections	Height (mm)	Width (mm)	Depth (mm)	Weight (kg)	Refrigeration-circuit Pre-filter (Oil/Water/Particulate)	Desiccant Pre-filter (Oil/Water/Particulate)	Desiccant Post-filter (Oil/Water/Particulate)
ATT 025	1"	1064	706	1246	180	GL9ZLP	GL9XLP	GL9ZLP
ATT 040	1"	1064	706	1246	200	GL11ZLP	GL11XLP	GL11ZLP
ATT 060	1 ½"	1214	806	1416	295	GL11ZLP	GL11XLP	GL11ZLP
ATT 090	1 ½"	1214	806	1416	335	GL12ZLP	GL12XLP	GL12ZLP
ATT 140	2"	1586	1007	1345	490	GL14ZLP	GL14XLP	GL14ZLP
ATT 260	2 ½"	1720	1007	2535	880	GL19ZLP	GL19XLP	GL19ZLP
ATT 340	2 ½"	1720	1007	2535	950	GL19ZLP	GL19XLP	GL19ZLP

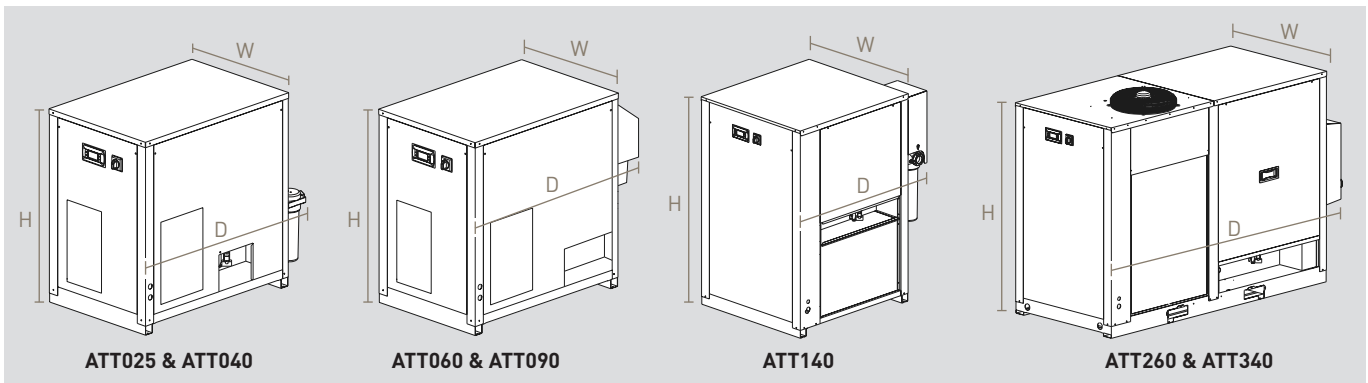

Pressure vessel approvals

Developed and manufactured to ISO 9001, ISO 14001, OHSAS18001
 Approval for fluid group 2 in accordance with the Pressure Equipment Directive 2014/68/EU.
 For use with compressed air and gaseous nitrogen.