

4x Klemmplatte für M12 (IPB)
(Im Lieferumfang enthalten)
4x clamping plate for M12 (IPB)
(included in delivery)

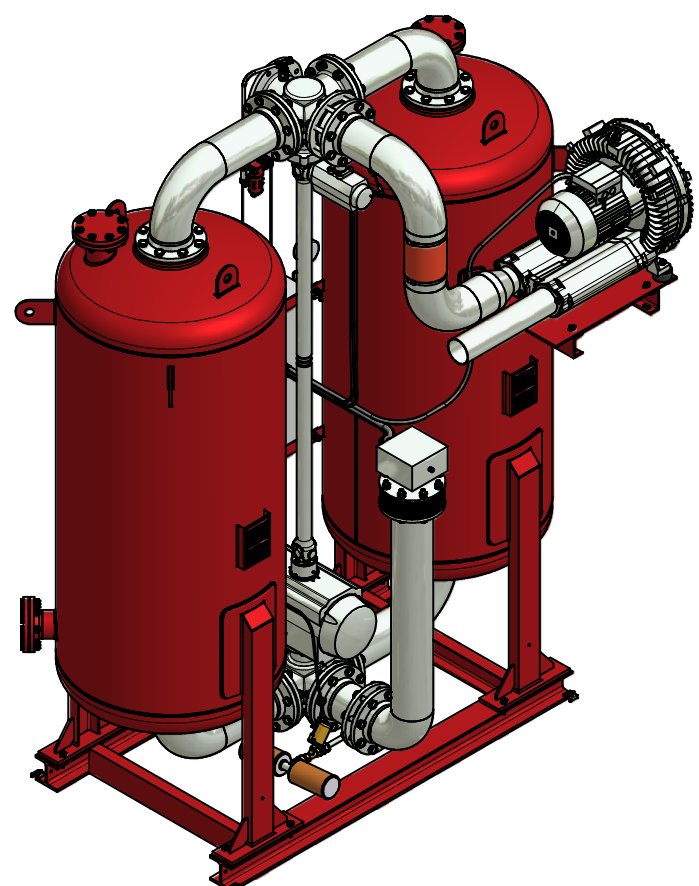
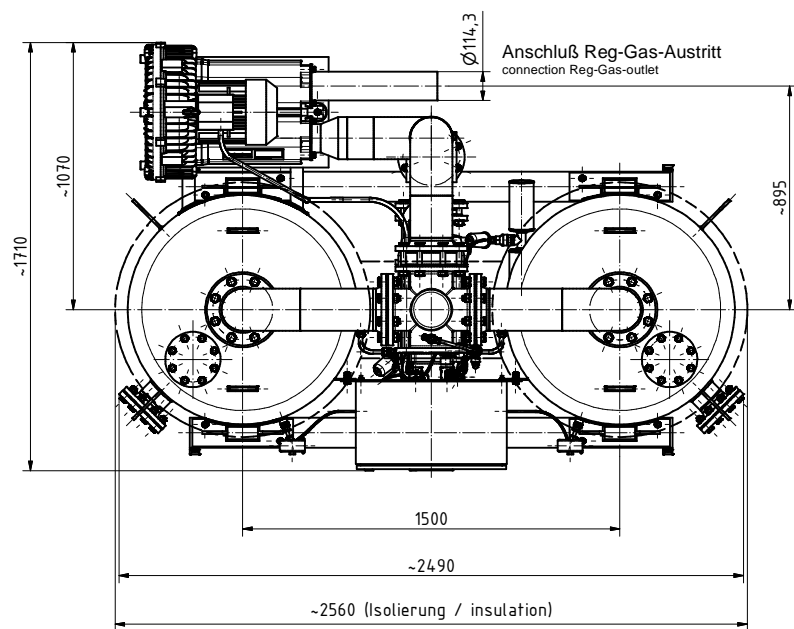
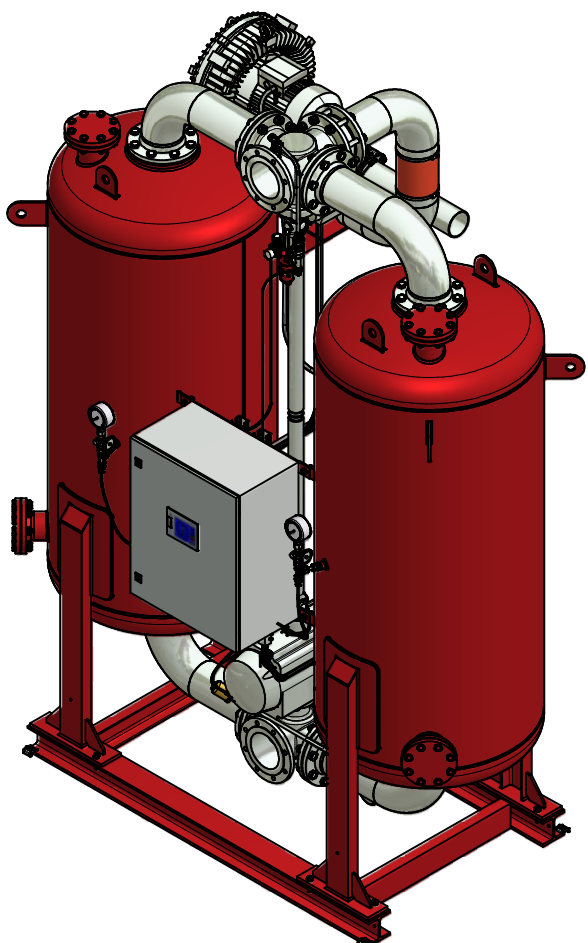

Option :

Isolierung und Berührungsschutz (Mehrgewicht zzgl. 95 kg)
Insulation and protection against contact (added weight plus)

Allgemeintoleranz General Tolerance DIN ISO 2768-mK		Oberflächen Surface DIN EN ISO 1302		DIN 6 Methode 1		Gewicht weight 4563 kg	
Datum/date 14.05.2009		Name Christoph Weiß		Maßstab / scale 1:1		Benennung / designation dryer	
Geprüft / checked 21.09.2010		Name Norbert Schmidt		Zeichnungs-Nr. / drawing-no. ENG-005417		Baugruppe 10 bar	
Umwelt- und Mißbrauchschutz nach DIN ISO 16018 / Copyright protection according to DIN ISO 16018		Parker Zander		Werkstoff / Material		WVM0475	