



Quality Incident Protection for the sparkling beverage industry

aerospace
climate control
electromechanical
filtration
fluid & gas handling
hydraulics
pneumatics
process control
sealing & shielding



ENGINEERING YOUR SUCCESS.

www.parker.com/dhfn

Contents

Introduction	1
Carbon dioxide contamination	3
ISBT quality guidelines	5
Sources and types of contamination	7
A dedicated solution for multiple applications	9
Quality system design	11
The Parker design philosophy	13
Performance validation	14
purecare™ schedule of services	15



Filtration, purification and separation is our business

Parker is a world leader in the filtration, purification and separation of compressed air and gases.

Parker specialises in purification and separation technologies where compressed air and gas purity, product quality, technological excellence and global support are paramount.

Parker designs and manufactures carbon dioxide Quality Incident Protection systems for the sparkling beverage industry to help preserve and guarantee the quality of gaseous carbon dioxide which is used in the industry.

Using the latest technology, the Quality Incident Protection systems remove a wide range of potential carbon dioxide impurities to guarantee the gas quality so that it remains within industry and company guidelines.

The carbon dioxide Quality Incident Protection systems from Parker are the beverage industries preferred choice and are installed in more than 150 countries worldwide.





Carbon dioxide contamination can be a real problem for the sparkling beverage industry

Recent improvements with on-site analytical equipment have revealed that traditional methods of protecting carbon dioxide quality are insufficient.

Potential carbon dioxide contamination may include residues which can be carried over from the feed source, from contaminants introduced into the bulk liquid carbon dioxide or from gas cylinders within the distribution system.

Some compounds are of particular concern to sparkling beverage manufacturers as they are known to have a negative impact on the flavour and appearance of the beverage.

Other compounds that are known to be detrimental to consumer safety are governed by regulatory control. Voluntary quality standards are listed in the ISBT quality guidelines which are shown on page 5.

Recent improvements with on-site analytical equipment have revealed that traditional methods of protecting the quality of carbon dioxide, such as passing the gas through an activated carbon bed, cannot protect or maintain the required gas quality.

The industry is also becoming increasingly aware of the serious impact of carbon dioxide impurities on the beverage's characteristics and the associated consequences of not ensuring its quality. This applies to all sparkling beverages, fountain / post mix as well as beer dispense.



ISBT quality guidelines for carbon dioxide

The International Society of Beverage Technologists (ISBT) is the only organisation whose sole interest is the technical and scientific aspects of soft drinks and beverages.

The ISBT is a highly respected body which is dedicated to the promotion, development and dissemination of knowledge relating to the art and science of beverage technology.

The quality guidelines and analytical procedure bibliography has been developed by the ISBT to provide guidance for manufacturers of carbonated beverages and suppliers of carbon dioxide to the carbonated beverage industries about key characteristics for the quality and purity of carbon dioxide when used as a direct food additive in beverages.

The following table lists the voluntary quality standards taken from the document with relation to CO₂ quality.

Voluntary quality standards as listed in the ISBT Quality Guidelines

Parameter	Guideline	Rationale†
Purity:	99.9 % v/v min.	Process
Moisture:	20 ppm v/v max.	Process
Oxygen:	30 ppm v/v max.	Sensory
Carbon Monoxide:	10 ppm v/v max.	Process
Ammonia	2.5 ppm v/v max.	Process
Nitric Oxide / Nitrogen Dioxide:	2.5 ppm v/v max. (each)	Regulatory
Non-volatile Residue:	10 ppm w/w max.	Sensory
Non-volatile Organic Residue:	5 ppm w/w max.	Sensory
Phosphine:	To pass test (0.3 ppm v/v max.)	Regulatory
Total Volatile Hydrocarbons: (as Methane)	50 ppm v/v max. including 20 ppm v/v max. as total non-methane hydrocarbons	Sensory
Acetaldehyde:	0.2 ppm v/v max.	Sensory
Aromatic Hydrocarbon Content:	20 ppb v/v max.	Regulatory
Total Sulphur Content* (as S): (*Total sulphur-containing impurities excluding sulphur dioxide)	0.1 ppm v/v max.	Sensory
Sulphur Dioxide	1 ppm v/v max.	Sensory
Odour of Solid CO ₂ (snow):	No foreign odour	Sensory
Appearance in water:	No colour or turbidity	Sensory
Odour and taste in water:	No foreign odour or taste	Sensory

Source: ISBT CO₂ quality & analytical procedure bibliography, 2009.

†Rationale definitions:

Sensory: Any attribute that negatively impacts the taste, appearance or odour of beverage.

Process: Any attribute that defines a key parameter in a controlled process and an important consideration in the beverage industry.

Regulatory: Any attribute whose limit is set by governing regulatory agencies.



Sources and types of contamination

Understanding the sources of CO₂ contamination and the types of contaminants which must be reduced or eliminated is a key factor in achieving acceptable product quality.

Prior to delivery, pure CO₂ is at risk of contamination from atmospheric air, transportation, storage and handling, which can take place up to several times before reaching the production plant.

Types of contaminants include non-volatile organic (NVOR) and non-volatile residues (NVR).



Oil vapour and grease

Atmospheric air contains oil in a gaseous form (oil vapour) and derives from inefficient industrial processes and vehicle exhausts. Other sources of oil and grease can emanate from transfer pumps and compressors. As with other contaminants, oil vapour is drawn into the compressor intake and passes through the intake filter. Typical concentrations can vary

between 0.05 and 0.5 mg per cubic metre, but these can increase significantly should the compressor be sited near highways. Additionally, lubricants used in the compression stage of a compressor can also be vapourised and carried over. Once inside the CO₂ distribution system, oil vapour will cool and condense into liquid oil.



Plasticiser compounds

Flexible hoses and rubber gaskets are typical sources for contaminating CO₂ with plasticiser compounds.

Liquid CO₂ is an extremely effective solvent which can extract plasticiser compounds very easily.



Rust and pipscale

Rust and pipscale can be directly attributed to the presence of water in liquid CO₂ storage tanks and distribution piping. Over time, the rust and pipscale breaks away to contaminate the CO₂. Rust and

pipiscale problems often increase for a period of time after the installation of PCO₂ system into older piping systems which were previously operated with inadequate or no purification equipment.



A dedicated solution for multiple applications

From production plant to fountain / post mix and beer dispense, guaranteed CO₂ purity is assured.

The PCO₂ carbon dioxide Quality Incident Protection system from Parker domnick hunter offers a comprehensive solution to preserve and guarantee the quality of gaseous carbon dioxide used in the sparkling beverage industry.

Using multi-layer gas adsorbent technology, the PCO₂ range includes Maxi and Mplus PCO₂ for plant scale protection, in addition to Midi and Mini PCO₂ designed

for fountain / post mix and beer dispense applications respectively.

Operating as a vapour absorber to remove a wide range of potentially harmful carbon dioxide impurities, the system guarantees the gas quality to remain within industry and company guidelines, therefore preventing detrimental consequences to the finished beverage and to the producers reputation.

Maxi PCO₂ and MPlus PCO₂ systems for production plant

The system for the production plant environment offers in-line quality incident protection against peak levels of trace impurities which may be present in beverage-grade carbon dioxide.

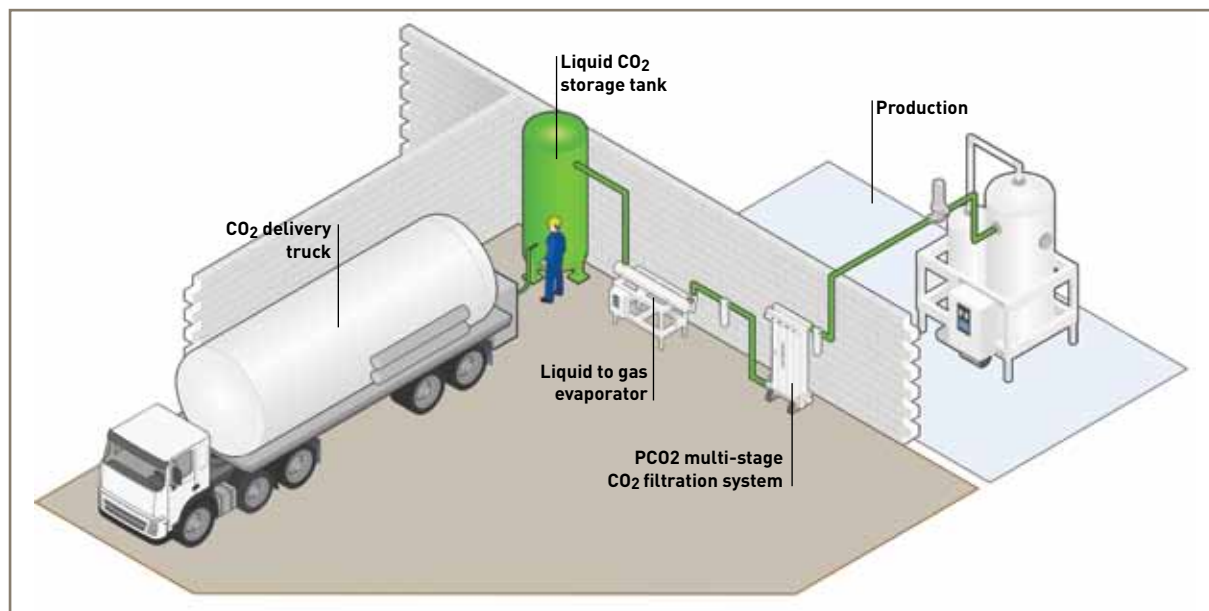

Typical production plant application

Nitrogen Quality Incident Protection

Whilst originally developed for the protection of carbon dioxide quality used in the beverage industry, the Parker domnick hunter PCO₂ system is also effective at removing trace levels of hydrocarbon contamination from nitrogen gas.

As part of the gas Quality Incident Protection system, the PCO₂ system can be used in a wide range of industries where the quality of the gas is critical i.e. life science research, bio-pharmaceutical, laboratory gases and electronics.



Quality system design

The latest multi-layer technology ensures the highest level of protection.

Six stage Quality Incident Protection technology

Maxi PCO2 and MPlus PCO2 offers six stages of carbon dioxide Quality Incident Protection from a compact, modular system to offer the highest level of production plant and point of use protection.

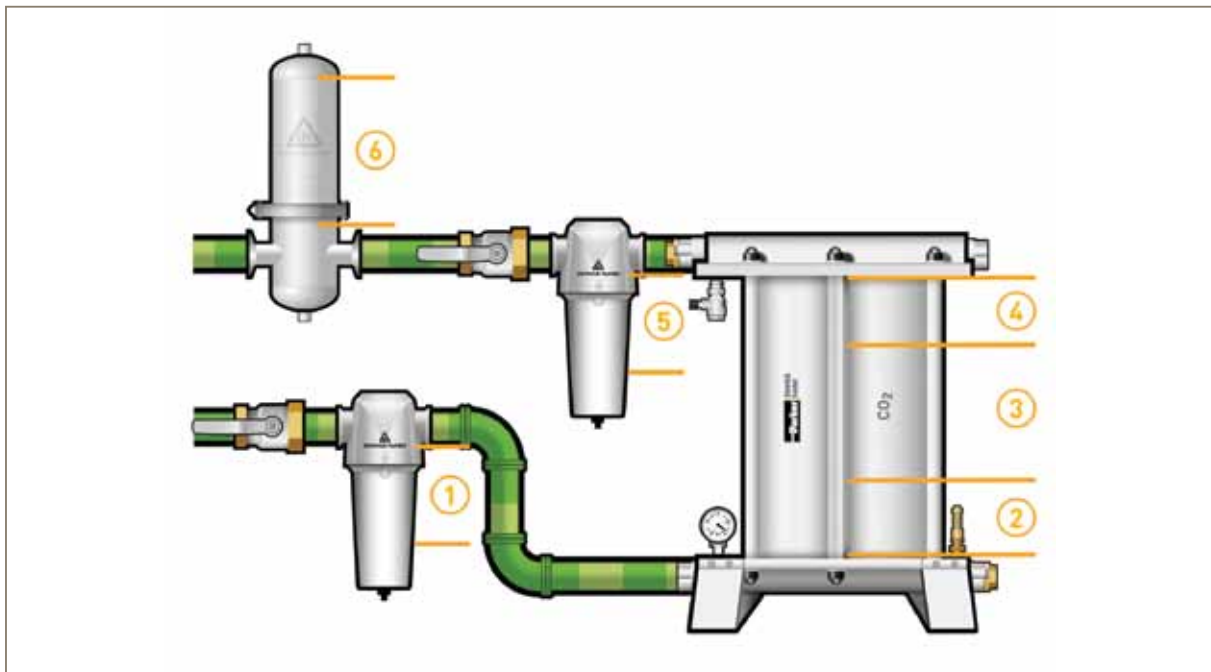

Stage 1

0.01 micron particle filtration
Removal of non-volatile organic residue (NVOR)
and other contaminants down to 0.01 ppm

Stage 2

Removal of water vapour and partial removal
of hydrocarbons

Stage 3

Primary removal of aromatic hydrocarbons
(Benzene, Toluene etc and Acetaldehyde)

Stage 4

Removal of sulphur compounds
(COS, H₂S, DMS etc)

Stage 5

0.01 micron particle filtration

Stage 6

Point of use VBACE sterile gas membrane.
Hi Flow Tetpor II

In addition to inlet and outlet particulate filtration, the plant scale systems incorporate a unique multi-layer adsorption bed, pre-loaded into cartridges for ease of maintenance.

The multi-layer materials used in the system have been carefully selected to preferentially adsorb potential impurities, thus ensuring optimum removal efficiency during the systems' operational life.

The removal efficiencies of the system at each stage

Preferential adsorption

Good Adsorption Partial Adsorption No Adsorption

Potential Contaminant		Purification Stage				
Name	Type	1 st Stage	2 nd Stage	3 rd Stage	4 th Stage	5 th Stage
NVR / NVOR	Particulate / Oil / Rust etc.	<input checked="" type="checkbox"/>	<input checked="" type="checkbox"/>	<input checked="" type="checkbox"/>	<input checked="" type="checkbox"/>	<input checked="" type="checkbox"/>
Moisture	Vapour	<input checked="" type="checkbox"/>	<input checked="" type="checkbox"/>	<input checked="" type="checkbox"/>	<input checked="" type="checkbox"/>	<input checked="" type="checkbox"/>
Benzene	Aromatic Hydrocarbon	<input checked="" type="checkbox"/>	<input checked="" type="checkbox"/>	<input checked="" type="checkbox"/>	<input checked="" type="checkbox"/>	<input checked="" type="checkbox"/>
Ethyl Benzene	Aromatic Hydrocarbon	<input checked="" type="checkbox"/>	<input checked="" type="checkbox"/>	<input checked="" type="checkbox"/>	<input checked="" type="checkbox"/>	<input checked="" type="checkbox"/>
Toluene	Aromatic Hydrocarbon	<input checked="" type="checkbox"/>	<input checked="" type="checkbox"/>	<input checked="" type="checkbox"/>	<input checked="" type="checkbox"/>	<input checked="" type="checkbox"/>
Xylene	Aromatic Hydrocarbon	<input checked="" type="checkbox"/>	<input checked="" type="checkbox"/>	<input checked="" type="checkbox"/>	<input checked="" type="checkbox"/>	<input checked="" type="checkbox"/>
Cyclohexane	Volatile Organic Hydrocarbon	<input checked="" type="checkbox"/>	<input checked="" type="checkbox"/>	<input checked="" type="checkbox"/>	<input checked="" type="checkbox"/>	<input checked="" type="checkbox"/>
Acetaldehyde	Volatile Organic Hydrocarbon	<input checked="" type="checkbox"/>	<input checked="" type="checkbox"/>	<input checked="" type="checkbox"/>	<input checked="" type="checkbox"/>	<input checked="" type="checkbox"/>
Propyl Alcohol	Volatile Organic Hydrocarbon	<input checked="" type="checkbox"/>	<input checked="" type="checkbox"/>	<input checked="" type="checkbox"/>	<input checked="" type="checkbox"/>	<input checked="" type="checkbox"/>
Dimethyl Ether	Volatile Organic Hydrocarbon	<input checked="" type="checkbox"/>	<input checked="" type="checkbox"/>	<input checked="" type="checkbox"/>	<input checked="" type="checkbox"/>	<input checked="" type="checkbox"/>
MIBK	Volatile Organic Hydrocarbon	<input checked="" type="checkbox"/>	<input checked="" type="checkbox"/>	<input checked="" type="checkbox"/>	<input checked="" type="checkbox"/>	<input checked="" type="checkbox"/>
Ethanol	Volatile Organic Hydrocarbon	<input checked="" type="checkbox"/>	<input checked="" type="checkbox"/>	<input checked="" type="checkbox"/>	<input checked="" type="checkbox"/>	<input checked="" type="checkbox"/>
Nitric Oxide	Toxic Gas	<input checked="" type="checkbox"/>	<input checked="" type="checkbox"/>	<input checked="" type="checkbox"/>	<input checked="" type="checkbox"/>	<input checked="" type="checkbox"/>
Nitrogen Dioxide	Toxic Gas	<input checked="" type="checkbox"/>	<input checked="" type="checkbox"/>	<input checked="" type="checkbox"/>	<input checked="" type="checkbox"/>	<input checked="" type="checkbox"/>
Sulphur Dioxide	Toxic Gas	<input checked="" type="checkbox"/>	<input checked="" type="checkbox"/>	<input checked="" type="checkbox"/>	<input checked="" type="checkbox"/>	<input checked="" type="checkbox"/>
Carbonyl Sulphide	Sulphur Compound	<input checked="" type="checkbox"/>	<input checked="" type="checkbox"/>	<input checked="" type="checkbox"/>	<input checked="" type="checkbox"/>	<input checked="" type="checkbox"/>
Hydrogen Sulphide	Sulphur Compound	<input checked="" type="checkbox"/>	<input checked="" type="checkbox"/>	<input checked="" type="checkbox"/>	<input checked="" type="checkbox"/>	<input checked="" type="checkbox"/>
Dimethyl Sulphide	Sulphur Compound	<input checked="" type="checkbox"/>	<input checked="" type="checkbox"/>	<input checked="" type="checkbox"/>	<input checked="" type="checkbox"/>	<input checked="" type="checkbox"/>
Propyl Sulphide	Sulphur Compound	<input checked="" type="checkbox"/>	<input checked="" type="checkbox"/>	<input checked="" type="checkbox"/>	<input checked="" type="checkbox"/>	<input checked="" type="checkbox"/>

Typical impurities found in CO₂ sourced from fermentation processes and the off flavours associated with them.

Acetaldehyde

Present in all beers. Typical 'apple' off-flavour at high concentrations.

DMS

- Desirable characteristic of some pale lager beer styles. Typical 'corn' off-flavour in some beers.

Benzene

- Carcinogenic compound - Regulatory control not detected at low levels by taste or smell.

Iso-Amyl

- Present in most beers. Typical 'banana' off-flavours occur at ppm levels.

The Parker design philosophy

In addition to CO₂ Quality Incident Protection systems, Parker offers a wide range of high quality compressed air purification solutions which are essential to all modern production facilities. It has an unrivalled reputation for delivering high quality products which are developed using The Parker design philosophy.



Parker has been supplying industry with high efficiency filtration and purification products since 1963. Our philosophy 'Designed for Air Quality & Energy Efficiency' ensures products

that not only provide the user with clean, high quality gas, but also with low lifetime costs and reduced carbon dioxide (CO₂) emissions.



Air Quality

Parker has been instrumental in the development of both ISO8573 and ISO12500, the international standards for compressed air quality and compressed air filter testing

respectively. All Parker products are designed to provide air quality in accordance with ISO8573-1:2001, the latest revision of this air quality standard.



Energy Efficiency

In these times of increasing energy costs, an efficient and cost effective manufacturing process is a major factor in maintaining the profitability and growth of your business. All Parker products are designed to not

only minimise the use of compressed air and electrical energy in their operation, but also to significantly reduce the operational costs of the compressor by minimising pressure loss.



Low Lifetime Costs

Equipment with a low purchase cost may turn out to be a poor investment in the long term. By guaranteeing air quality and ensuring energy consumption is kept to a minimum,

Parker purification products can reduce the total cost of ownership and help improve profitability through improved manufacturing efficiencies.



Reduced CO₂ Emissions

Many countries worldwide are looking closely at their manufacturing industries in an effort to reduce the amount of harmful greenhouse gases released into the atmosphere. The use of electricity has a direct impact on

the generation and release of CO₂. By significantly reducing the energy consumption of its products, Parker can help you to reduce your carbon footprint and protect the environment.

Performance validation

Comprehensive testing has been carried out to verify the performance of the PCO2 system.

Conducted under controlled conditions, a set dilution ratio of specially prepared contaminated carbon dioxide mixed with a clean supply was flowed through a PCO2 unit at a set pressure and flow rate.

Gas samples were taken directly from the unit both upstream and downstream and were analysed by an independent analytical laboratory to evaluate the systems'

efficiency at removing trace contaminants. Removal of up to 10 times ISBT guidelines for stated impurities.

The results confirm the systems' ability to remove trace contaminants. The system also has the independent verification from Lloyd's Register.

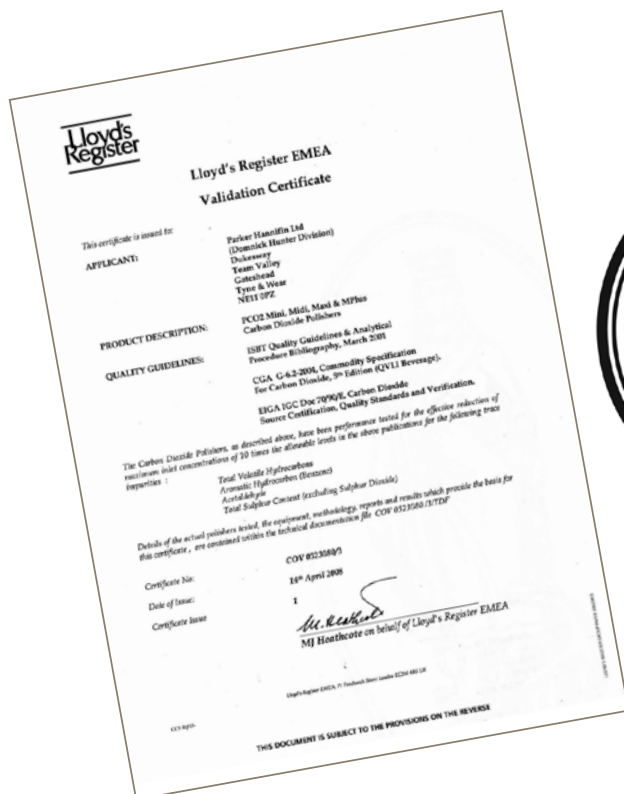

INTERNATIONAL APPROVALS



CRN

ASME VIII National Board

AS1210



Druckluft
effizient

Aftermarket

ELEMENTS

Parker filters are designed to produce clean compressed air, gas and liquid to the highest industry standards. To maintain impeccable results, Elements within the filter must be replaced annually.

Choosing the Parker brand means you can be assured that Elements are readily available, affordable and the most energy efficient product of its kind on the market. The elements are also supplied in 100% recyclable packaging. An additional advantage of purchasing Parker Elements is that you will reduce your company's carbon footprint by 190kg. This is the equivalent of a 700 mile flight from Edinburgh to Berlin!

Parker Filter Elements also prove to be highly efficient when used in any leading competitor's filters.

SPECIALISED SERVICES

Parker Specialist Service Engineers test on-site efficiency measuring many variables including airflow, pressure, temperature, dewpoint and power consumption.

Our team of highly trained experts are the best in the industry. They take into account a range of environmental factors that could affect your system's performance. The results from this Specialist Service are extremely accurate and produce invaluable information.

Importantly, Parker informed recommendations lead to significant savings for our customers, which mean they return time and time again for our advice and products.

SUPPORT SERVICES

Parker Support Services are the first port of call for customers in need of help or guidance.

The fact that this team is responsible for the production of User Guides and Manuals gives you an insight into the level and detail of their parts and product knowledge.

Over-the-phone support is just one way in which Parker's extremely knowledgeable team, quickly reduces downtime or resolves product queries.

On some occasions engineers need to be on site to carry out a repair. In these cases, the local engineer will be quickly dispatched to ensure our customers can return to production as soon as possible.

One-to-one training can also be provided by our Support Services team. This has enabled hundreds of Parker distributors to gain an in-depth understanding. Training will also ensure distributors can make timely repairs and easily maintain their customers' products.

PARTS

Parker Kits make everyday maintenance easy. They are available for all of our products and are simply value-for-money. The Parts within the kits support our customers' varied maintenance, repair and overhaul activities.

Additionally, Preventative Maintenance Kits can be purchased for dryers and gas generators. These kits mean our customers dryer's and generator's can be serviced easily to ensure optimum performance.

An extensive range of durable Parker Parts can be obtained within 24 hours to any European, Middle East or African destination.

M.R.O.

Maintenance Repair & Overhaul - Parker Technicians are the industry's finest. Their skills and qualifications are annually approved to keep their product and legislation knowledge fresh and expertise relevant.

With this in mind, Parker offers onsite and on demand servicing to meet customers' unique requirements in a timely and efficient manner.

Parker MRO service ranges from a basic maintenance check covered under product warranty right through to a comprehensive programme, which even puts the onsite application under the microscope.

With customers at the heart of everything Parker does, the MRO service is no exception to this.





Parker's Motion & Control Technologies

At Parker, we're guided by a relentless drive to help our customers become more productive and achieve higher levels of profitability by engineering the best systems for their requirements. It means looking at customer applications from many angles to find new ways to create value. Whatever the motion and control technology need, Parker has the experience, breadth of product and global reach to consistently deliver. No company knows more about motion and control technology than Parker. For further info call 00800 27 27 5374



Aerospace

Key Markets

Aftermarket services
Commercial transports
Engines
General & business aviation
Helicopters
Launch vehicles
Military aircraft
Missiles
Power generation
Regional transports
Unmanned aerial vehicles

Key Products

Control systems & actuation products
Engine systems & components
Fluid conveyance systems & components
Fluid metering, delivery & atomization devices
Fuel systems & components
Fuel tank inerting systems
Hydraulic systems & components
Thermal management
Wheels & brakes



Climate Control

Key Markets

Agriculture
Air conditioning
Construction Machinery
Food & beverage
Industrial machinery
Life sciences
Oil & gas
Precision cooling
Process
Refrigeration
Transportation

Key Products

Accumulators
Advanced actuators
CO₂ controls
Electronic controllers
Filter driers
Hand shut-off valves
Heat exchangers
Hose & fittings
Pressure regulating valves
Refrigerant distributors
Safety relief valves
Smart pumps
Solenoid valves
Thermostatic expansion valves



Electromechanical

Key Markets

Aerospace
Factory automation
Life science & medical
Machine tools
Packaging machinery
Paper machinery
Plastics machinery & converting
Primary metals
Semiconductor & electronics
Textile
Wire & cable

Key Products

AC/DC drives & systems
Electric actuators, gantry robots & slides
Electrohydraulic actuation systems
Electromechanical actuation systems
Human machine interface
Linear motors
Stepper motors, servo motors, drives & controls
Structural extrusions



Filtration

Key Markets

Aerospace
Food & beverage
Industrial plant & equipment
Life sciences
Marine
Mobile equipment
Oil & gas
Power generation & renewable energy
Process
Transportation
Water Purification

Key Products

Analytical gas generators
Compressed air filters & dryers
Engine air, coolant, fuel & oil filtration systems
Fluid condition monitoring systems
Hydraulic & lubrication filters
Hydrogen, nitrogen & zero air generators
Instrumentation filters
Membrane & fiber filters
Microfiltration
Sterile air filtration
Water desalination & purification filters & systems



Fluid & Gas Handling

Key Markets

Aerial lift
Agriculture
Bulk chemical handling
Construction machinery
Food & beverage
Fuel & gas delivery
Industrial machinery
Life sciences
Marine
Mining
Mobile
Oil & gas
Renewable energy
Transportation

Key Products

Check valves
Connectors for low pressure fluid conveyance
Deep sea umbilicals
Diagnostic equipment
Hose couplings
Industrial hose
Mooring systems & power cables
PTFE hose & tubing
Quick couplings
Rubber & thermoplastic hose
Tube fittings & adapters
Tubing & plastic fittings



Hydraulics

Key Markets

Aerial lift
Agriculture
Alternative energy
Construction machinery
Forestry
Industrial machinery
Machine tools
Marine
Material handling
Mining
Oil & gas
Power generation
Refuse vehicles
Renewable energy
Truck hydraulics
Turf equipment

Key Products

Accumulators
Cartridge valves
Electrohydraulic actuators
Human machine interfaces
Hybrid drives
Hydraulic cylinders
Hydraulic motors & pumps
Hydraulic systems
Hydraulic valves & controls
Hydrostatic steering
Integrated hydraulic circuits
Power take-offs
Power units
Rotary actuators
Sensors



Pneumatics

Key Markets

Aerospace
Conveyor & material handling
Factory automation
Life science & medical
Machine tools
Packaging machinery
Transportation & automotive

Key Products

Air preparation
Brass fittings & valves
Manifolds
Pneumatic accessories
Pneumatic actuators & grippers
Pneumatic valves & controls
Quick disconnects
Rotary actuators
Rubber & thermoplastic hose & couplings
Structural extrusions
Thermoplastic tubing & fittings
Vacuum generators, cups & sensors



Process Control

Key Markets

Alternative fuels
Biopharmaceuticals
Chemical & refining
Food & beverage
Marine & shipbuilding
Medical & dental
Microelectronics
Nuclear Power
Offshore oil exploration
Oil & gas
Pharmaceuticals
Power generation
Pulp & paper
Steel
Water/wastewater

Key Products

Analytical Instruments
Analytical sample conditioning products & systems
Chemical injection fittings & valves
Fluoropolymer chemical delivery fittings, valves & pumps
High purity gas delivery fittings, valves, regulators & digital flow controllers
Industrial mass flow meters/controllers
Permanent no-weld tube fittings
Precision industrial regulators & flow controllers
Process control double block & bleeds
Process control fittings, valves, regulators & manifold valves



Sealing & Shielding

Key Markets

Aerospace
Chemical processing
Consumer
Fluid power
General industrial
Information technology
Life sciences
Microelectronics
Military
Oil & gas
Power generation
Renewable energy
Telecommunications
Transportation

Key Products

Dynamic seals
Elastomeric o-rings
Electro-medical instrument design & assembly
EMI shielding
Extruded & precision-cut, fabricated elastomeric seals
High temperature metal seals
Homogeneous & inserted elastomeric shapes
Medical device fabrication & assembly
Metal & plastic retained composite seals
Shielded optical windows
Silicone tubing & extrusions
Thermal management
Vibration dampening

ENGINEERING YOUR SUCCESS.

Parker Worldwide

Europe, Middle East, Africa

AE – United Arab Emirates, Dubai

Tel: +971 4 8127100
parker.me@parker.com

AT – Austria, Wiener Neustadt

Tel: +43 (0)2622 23501-0
parker.austria@parker.com

AT – Eastern Europe, Wiener Neustadt

Tel: +43 (0)2622 23501 900
parker.easteurope@parker.com

AZ – Azerbaijan, Baku

Tel: +994 50 2233 458
parker.azerbaijan@parker.com

BE/LU – Belgium, Nivelles

Tel: +32 (0)67 280 900
parker.belgium@parker.com

BG – Bulgaria, Sofia

Tel: +359 2 980 1344
parker.bulgaria@parker.com

BY – Belarus, Minsk

Tel: +375 17 209 9399
parker.belarus@parker.com

CH – Switzerland, Etoy

Tel: +41 (0)21 821 87 00
parker.switzerland@parker.com

CZ – Czech Republic, Klecany

Tel: +420 284 083 111
parker.czechrepublic@parker.com

DE – Germany, Kaarst

Tel: +49 (0)2131 4016 0
parker.germany@parker.com

DK – Denmark, Ballerup

Tel: +45 43 56 04 00
parker.denmark@parker.com

ES – Spain, Madrid

Tel: +34 902 330 001
parker.spain@parker.com

FI – Finland, Vantaa

Tel: +358 (0)20 753 2500
parker.finland@parker.com

FR – France, Contamine s/Arve

Tel: +33 (0)4 50 25 80 25
parker.france@parker.com

GR – Greece, Athens

Tel: +30 210 933 6450
parker.greece@parker.com

HU – Hungary, Budaörs

Tel: +36 23 885 470
parker.hungary@parker.com

IE – Ireland, Dublin

Tel: +353 (0)1 466 6370
parker.ireland@parker.com

IT – Italy, Corsico (MI)

Tel: +39 02 45 19 21
parker.italy@parker.com

KZ – Kazakhstan, Almaty

Tel: +7 7273 561 000
parker.easteurope@parker.com

NL – The Netherlands, Oldenzaal

Tel: +31 (0)541 585 000
parker.nl@parker.com

NO – Norway, Asker

Tel: +47 66 75 34 00
parker.norway@parker.com

PL – Poland, Warsaw

Tel: +48 (0)22 573 24 00
parker.poland@parker.com

PT – Portugal, Leca da Palmeira

Tel: +351 22 999 7360
parker.portugal@parker.com

RO – Romania, Bucharest

Tel: +40 21 252 1382
parker.romania@parker.com

RU – Russia, Moscow

Tel: +7 495 645-2156
parker.russia@parker.com

SE – Sweden, Spånga

Tel: +46 (0)8 59 79 50 00
parker.sweden@parker.com

SK – Slovakia, Banská Bystrica

Tel: +421 484 162 252
parker.slovakia@parker.com

SL – Slovenia, Novo Mesto

Tel: +386 7 337 6650
parker.slovenia@parker.com

TR – Turkey, Istanbul

Tel: +90 216 4997081
parker.turkey@parker.com

UA – Ukraine, Kiev

Tel: +380 44 494 2731
parker.ukraine@parker.com

UK – United Kingdom, Warwick

Tel: +44 (0)1926 317 878
parker.uk@parker.com

ZA – South Africa, Kempton Park

Tel: +27 (0)11 961 0700
parker.southafrica@parker.com

North America

CA – Canada, Milton, Ontario

Tel: +1 905 693 3000

US – USA, Cleveland

Tel: +1 216 896 3000

Asia Pacific

AU – Australia, Castle Hill

Tel: +61 (0)2-9634 7777

CN – China, Shanghai

Tel: +86 21 2899 5000

HK – Hong Kong

Tel: +852 2428 8008

IN – India, Mumbai

Tel: +91 22 6513 7081-85

JP – Japan, Tokyo

Tel: +81 (0)3 6408 3901

KR – South Korea, Seoul

Tel: +82 2 559 0400

MY – Malaysia, Shah Alam

Tel: +60 3 7849 0800

NZ – New Zealand, Mt Wellington

Tel: +64 9 574 1744

SG – Singapore

Tel: +65 6887 6300

TH – Thailand, Bangkok

Tel: +662 186 7000-99

TW – Taiwan, Taipei

Tel: +886 2 2298 8987

South America

AR – Argentina, Buenos Aires

Tel: +54 3327 44 4129

BR – Brazil, Sao Jose dos Campos

Tel: +55 800 727 5374

CL – Chile, Santiago

Tel: +56 2 623 1216

MX – Mexico, Toluca

Tel: +52 72 2275 4200

European Product Information Centre

Free phone: 00 800 27 27 5374

(from AT, BE, CH, CZ, DE, DK, EE, ES, FI, FR, IE, IL, IS, IT, LU, MT, NL, NO, PL, PT, RU, SE, SK, UK, ZA)



Parker Hannifin Ltd.

domnick hunter Industrial Division
Dukesway, Team Valley Trading Estate
Gateshead, Tyne and Wear
England NE11 0PZ
Tel: +44 (0)191 402 9000
Fax: +44 (0)191 482 6296
www.parker.com/dhfn