

4x Klemmplatte für M12 (IPB)
(Im Lieferumfang enthalten)
4x clamping plate for M12 (IPB)
(included in delivery)

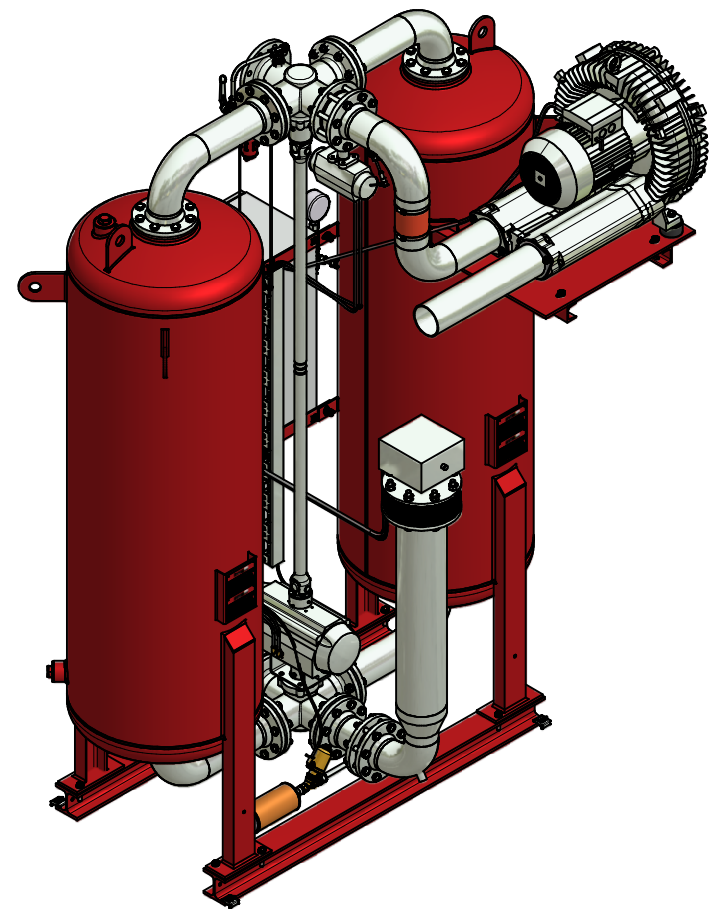
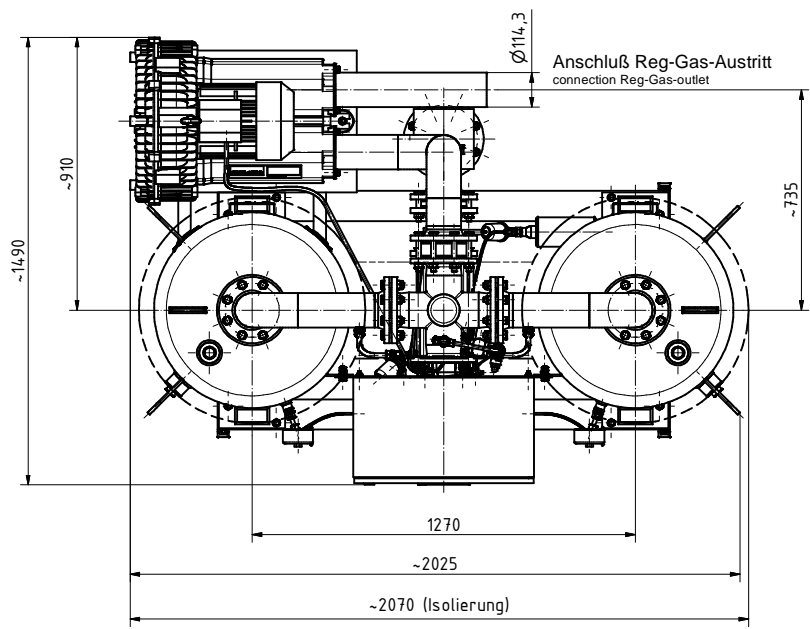
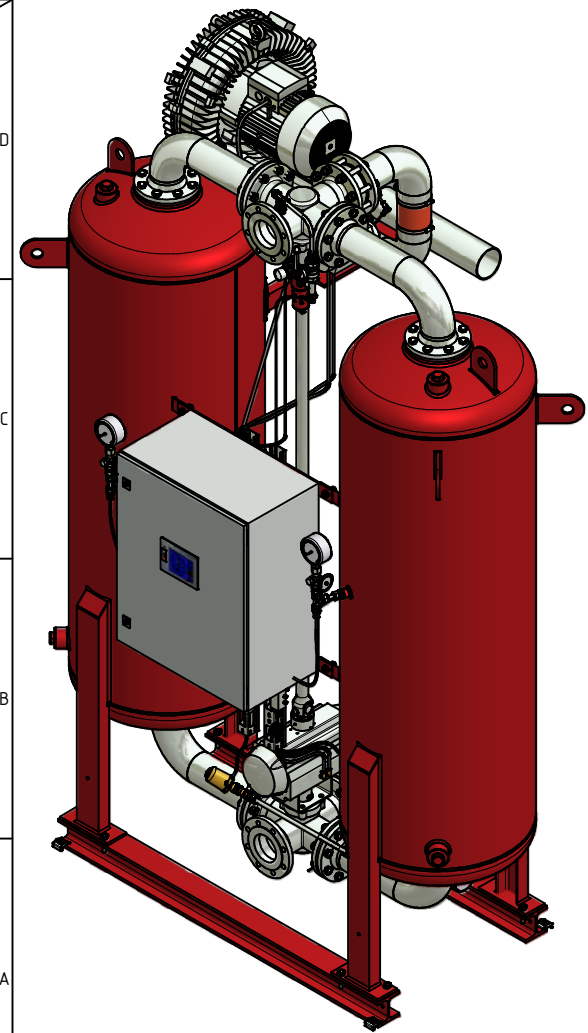

Option :

Isolierung und Berührungsschutz (Mehrgewicht zzgl. 85 kg)
Insulation and protection against contact (added weight plus 85 kg)

Allgemeintoleranz General Tolerance DIN ISO 2768-mK		Oberflächen Surface DIN EN ISO 1302		Werkstoff / Material Gewicht weight	
Datum/date 03.03.2009		Name Christoph Weiß		DIN 6 Methode 1 Maßstab / scale : 1:1	
E-Mail / email 07.07.2010		Name Norbert Schmidt		Benennung / designation dryer	
Trockner WVM0235 Baugruppe 10 bar		Zeichnungs-Nr. / drawing-no. ENG-004798		Parker Zander	
Index / Änderung/revision Datum/date Name		Hersteller / Manufacturer DIN EN ISO 15018 / Copyright protection according to DIN ISO 16016		WVM0235	