

12 11 10 9 8 7 6 5 4 3 2 1

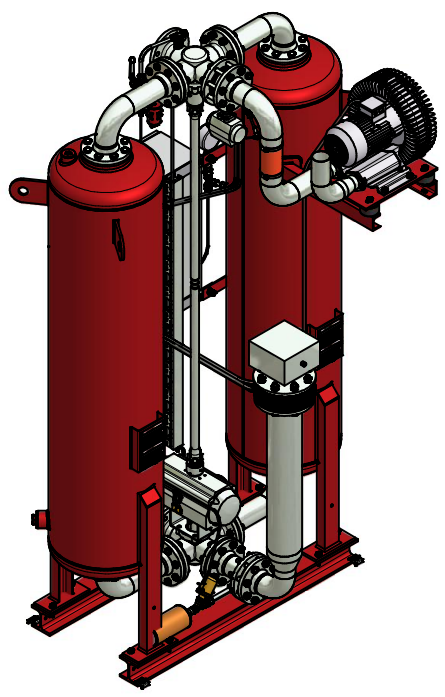
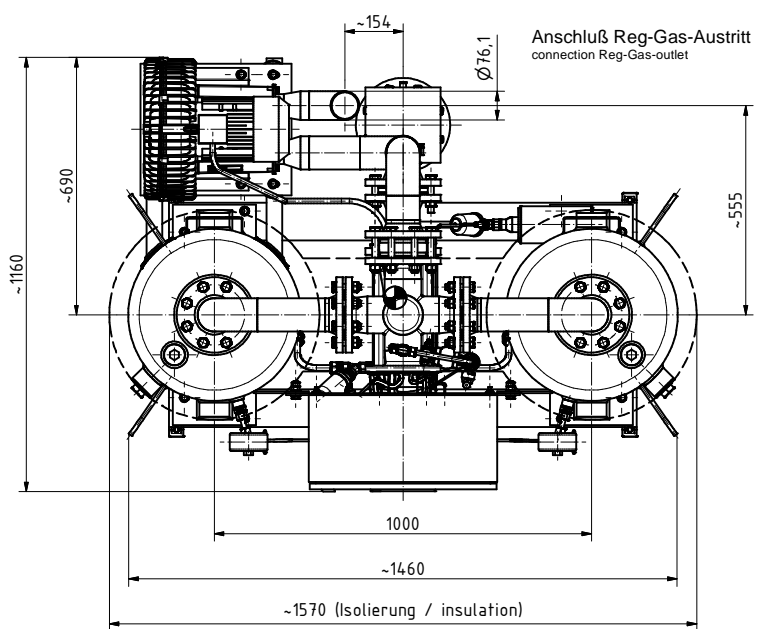
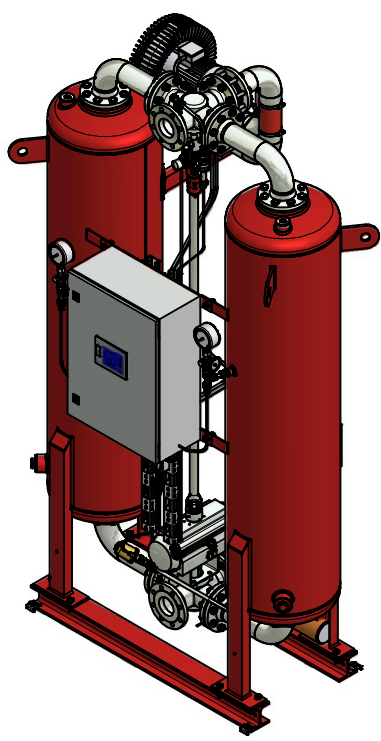
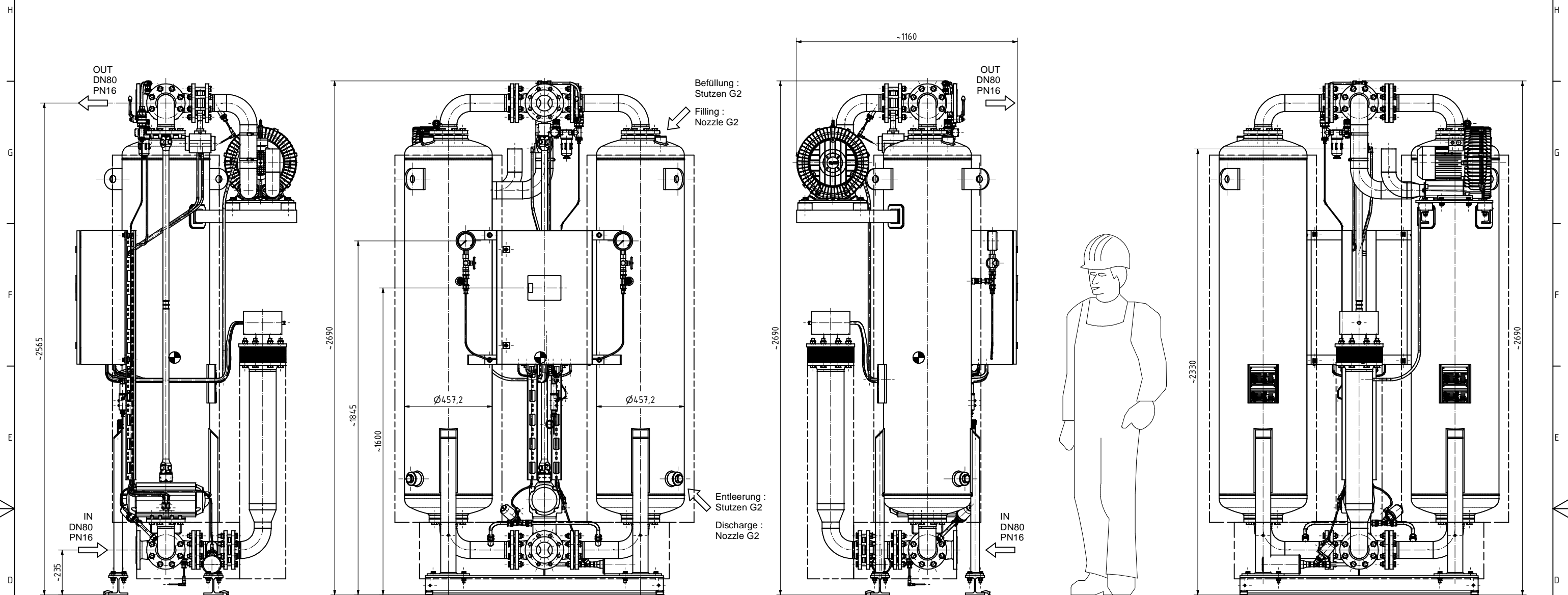

● **Schwerpunktmarkierung**

Option :

Isolierung und Berührungsschutz (Mehrgewicht zzgl. 85 kg)  
Insulation and protection against contact (added weight plus 85 kg)

Katalog-Nr. / Catalog-No.		Werkstoff / Material		Gewicht / weight
				1452 kg
Allgemeintoleranz / General Tolerance	Oberflächen / Surface	DIN 6 Methode 1		
DIN ISO 2768-mK	DIN EN ISO 1302	Maßstab / scale:		
Datum/date	Name	Benennung / designation:		
11.03.2009	Christoph Weiß	dryer		
07.04.2010	Norbert Schmidt	Trockner		
11.11.2010	Norbert Schmidt	WVM0120		
		Baugruppe 10 bar		
		Zeichnungs-Nr. / drawing-no.:		
		ENG-004601		
A	ECO-T10-004	11.11.10	CW543	<b>Parker</b> Zander
Index / Änderung/revision		Datum/date		Name
Umwelt- und Maßbrauchsschutz nach DIN ISO 16018 / Copyright protection according to DIN ISO 16018		Entwurf / design		Zeichner / drafter
				WVM0120

12 11 10 9 8 7 6 5 4 3 2 1