

4x Klemmplatte für M12 (IPB)  
(Im Lieferumfang enthalten)  
4x clamping plate for M12 (IPB)  
(included in delivery)

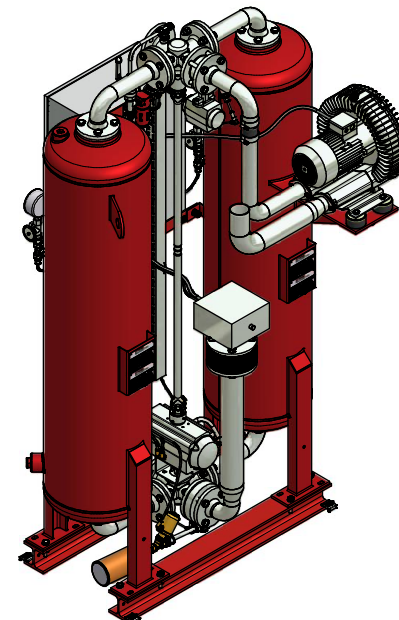
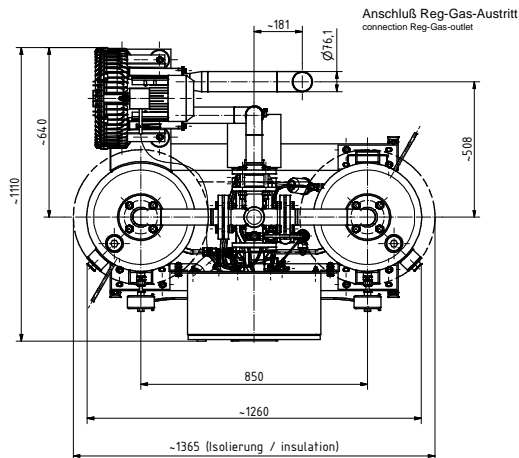
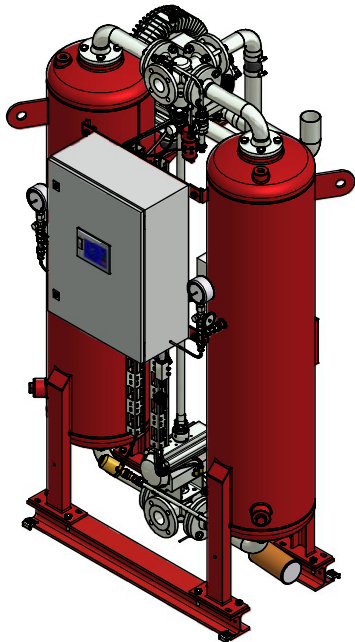
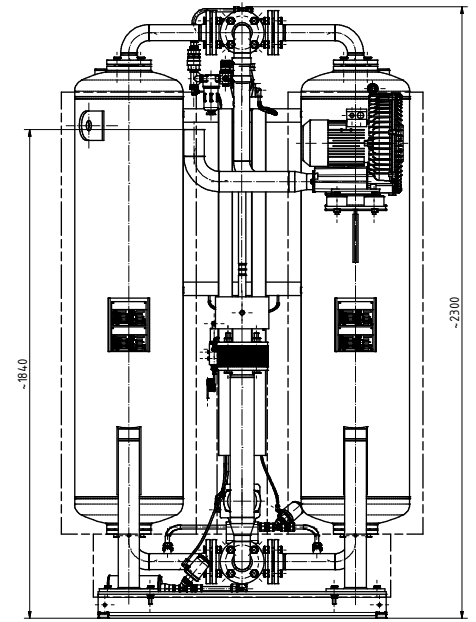

**Option :**

----- Isolierung und Berührungsschutz (Mehrgewicht zzgl. ca.85 kg)  
Insulation and protection against contact (added weight plus)

Artikel-Nr. / Article-no. 3225-40004201		Werkstoff / Material		Gewicht weight ~1025 kg
Algemeintoleranz General Tolerance DIN ISO 2768-mS	Oberflächen Surface DIN EN ISO 1300	 		 
Datum Date 18.02.2009 Gepr. / checked 21.07.2010 Gepr. / checked Name Bernd Schmidt	Name Bernd Schmidt	Berechnung / Calculation dryer WWM0065-0085 Baugruppe 10 bar		Zeichnungs-Nr. / drawing no. ENG-004151
		Parker Zander		Werkstoff Material IPB