

OPERATING/ASSEMBLY INSTRUCTIONS



Illustration exemplary

Pressure
vessel type:
PVA / VBA

pure! GmbH
Konrad-Zuse-Straße 5
D-65549 Limburg
Phone+496431 49612 40
Fax+496431 49612 41

E-Mail: support@pure-gmbh.com
Website: <http://www.pure-gmbh.com>

Ident. no.: PVA-pure DE Rev. 0
Issue 01/2018

NOTE



These operating/assembly instructions are part of the pressure vessel and must be available to the operating and maintenance personnel at all times. The safety instructions contained therein must be observed.

If the pressure vessel is resold, the operating/assembly instructions must be supplied with it or downloaded from the Internet site https://www.pure-gmbh.com/userdata/filegallery/original/bedienungsanleitung_druckbehaelter_pva.pdf.

Translation

The operating instructions must be written in an official language of the European Community that is accepted by the manufacturer of the machine/plant in which the pressure vessel is to be installed or by his authorised representative. If there are any discrepancies in the translated text, the original operating instructions (German) must be consulted for clarification or the manufacturer contacted.

This manual and all illustrations contained in it are protected by copyright. Any use outside the limits of copyright law without the prior written consent of the publisher is prohibited and liable to prosecution. This applies in particular to duplications, translations, microfilming, storage and processing in electronic systems.

Content

.....	List of Figures	II
1 Introduction	1	
1.1 Means of representation	2	
1.2 Abbreviations	3	
1.3 Guarantee, warranty	and liability	4
2 Security	5	
2.1 Intended	use	6
2.2 Marking of the	pressure vessel	6
2.2.1 Nameplate	7	
2.3 Hazard statements	7	
2.3.1 Dangers	7	
2.3.2 Danger area of	the pressure vessel	8
2.3.3 Installation of	spare and wear parts	9
2.3.4 Shutdown procedure	9	
2.4 Duties of the	operator	10
2.5 Safety measures (to be	carried out by the operator	11
2.6 Qualification requirements for	staff	12
2.7 Personal	protective equipment	12
3 Overview and	function	14
3.1 Overview/structure	14	
3.2 Function	15	
4 Technical	data	16
5 Installation	18	
5.1 Delivery	and transport	18
5.2 Line-up	20	
5.3 Assembly	21	
6 Commissioning	23	
7 Maintenance/Cleaning	25	
7.1 Closing and opening the	pressure vessel	26
7.2 Cleaning/maintenance intervals	27	
7.3 Notes on	cleaning	27
7.4 Spare parts inventory	28	
8 Disruptions	29	
8.1 Safety instructions	29	
8.2 Emergency behaviour	30	
9 Decommissioning/disposal	31	
9.1 Disposal	32	

Index 35

List of figures

Fig. 3-1:	Overview	14
Fig. 4-1: Draft	nameplate	16

1 Introduction

These operating/assembly instructions (hereinafter referred to as instructions) provide you with all the information you need for the smooth operation of the pressure vessel.

The instructions apply to the variants

- Pressure vessel for liquids without filter,
- Pressure vessel for gases without filter,

In principle, these instructions apply to all versions. Differences between the versions are clearly indicated.

These instructions must be read, understood and applied by all persons who are responsible for the installation, maintenance, cleaning and troubleshooting of the pressure vessel. This applies in particular to the safety instructions listed.

After studying the instructions you can

- assemble and operate the pressure vessel in a safe manner,
- clean and maintain the pressure vessel in accordance with the regulations and
- take the right action when a malfunction occurs.

In addition to the instructions, generally applicable, statutory and other binding regulations for accident prevention and environmental protection in the country of use must be observed.

The instructions must always be kept at the place of use of the pressure vessel or be available. If necessary download the instruction from the Internet page https://www.pure-gmbh.com/userdata/filegallery/original/bedienungsanleitung_druckbehaelter_pva.pdf.

1.1 Means of representation

As an indication and direct warning of dangers, text statements in these instructions that require special attention are marked as follows:



DANGER

This warning describes a hazard with a high degree of risk which, if not avoided, will result in death or serious injury.



WARNING

This warning describes a hazard with a medium level of risk which, if not avoided, may result in death or serious injury.



CAUTION

This warning describes a hazard with a low degree of risk which, if not avoided, may result in minor or moderate bodily injury.

NOTE

This warning describes a hazard with a low degree of risk which, if not avoided, may result in property damage.



The info icon gives useful information.

Embedded warnings

The embedded warnings apply to specific actions and are directly integrated into the action before the specific action step.

⚠ -DANGER / WARNING / CAUTION

- NOTE

Furthermore, the following means of representation are used:

- Texts that follow this marking are enumerations.
Texts following this marking describe activities to be carried out in the given order.
- " " Text in inverted commas are references to other chapters or sections.

Symbols used



Crushing hazards are marked with this symbol.



Burn hazards are marked with this symbol.



Dangers due to suspended loads are marked with this symbol.



'Follow instructions' is marked with this symbol.



Environmental protection measures are marked with this symbol.



Warning of substances hazardous to water is marked with this symbol.

Symbols used on the pressure vessel

Keep all safety and danger notices on the machine in a legible condition and renew them as necessary.



Burn hazards are marked with this symbol

1.2 Abbreviations

AWH	Armaturenwerk Hötensleben GmbH
BetrSichV	Ordinance on Industrial Safety and Health; Ordinance on Safety and Health in the Use of Work Equipment; German implementation of Directive 2009/104/EC of the European Parliament and of the Council concerning the minimum safety and health requirements for the use of work equipment.
	in the case of use of work equipment by employees at work
DIN	Deutsches Institut für Normung e.V.; is a national standardisation organisation in the Federal Republic of Germany; standards of this organisation are referred to as DIN standards.
DN	Nominal width
PED	Directive Pressure Equipment 2014/68/EU (Pressure Equipment Directive)
EN	European Standard

EWG	European Economic Community
EEA	European Economic Area
max.	maximum
MSR	Measuring, control and regulating equipment
PN	Nominal pressure
PTFE	Poly-Tetra-Fluor-Ethylene (sealing material)
Ra	Centre-line roughness (measure of surface roughness)

1.3 Guarantee, warranty and liability

Warranty

If the pressure vessel is used for its intended purpose, a warranty is granted in accordance with the statutory warranty obligation. Wear parts are excluded from this.

Increased wear due to abrasive media is not a defect in the product. Claims resulting from this cannot be taken into account in the guarantee.

Warranty and liability

The obligations agreed in the delivery contract, the General Terms and Conditions as well as the delivery conditions of Armaturenwerk Hötensleben GmbH (hereinafter referred to as AWH) and the legal regulations valid at the time of conclusion of the contract shall apply.

Warranty and liability claims for personal injury and property damage are excluded in particular if they are attributable to one or more of the following causes:

- improper or unintended use of the pressure vessel,
- improper installation, commissioning, operation and maintenance of the pressure vessel,
- Failure to observe the instructions in the manual regarding installation, commissioning, operation and maintenance of the pressure vessel,
- structural modifications to the pressure vessel (conversions or other modifications to the pressure vessel may not be carried out without the prior written consent of AWH. This also applies to welding work, drilling and cut-off grinding. In case of infringement, the pressure vessel loses conformity and the operating permit),
- Use of spare parts that do not comply with the technically specified requirements,
- improperly carried out repairs,
- Catastrophic events, foreign body impact and force majeure.

Disclaimer

AWH reserves the right to make changes to this document at any time without notice. AWH makes no warranty (express or implied) with respect to any information in this document, including but not limited to the implied warranties of merchantability and fitness for a particular purpose. In addition, AWH does not warrant the accuracy or completeness of any information, text, graphics or other items in this document.

2 Security

The pressure vessel has been built according to the state of the art and the recognised safety rules. Nevertheless, dangers to life and limb of the user or third parties or impairments of the pressure vessel and other material assets may occur during use due to the function.

The following basic safety instructions are intended to prevent personal injury and damage to property. The operator must ensure that the basic safety instructions are observed and complied with.

This manual contains basic instructions to be observed for the installation, operation, maintenance and servicing of the pressure vessel.

Every person entrusted with the installation, operation, maintenance and servicing must have read and understood these instructions.

The safety systems and safety instructions described in this manual must be observed.



WARNING



Non-observance of these instructions, improperly performed installation and repair work or incorrect operation can lead to malfunctions of the pressure vessel and to dangerous situations!

Death or serious bodily injury can be the result.

- Have all work on the pressure vessel carried out by a specialist only, paying particular attention to the following***
 - the associated detailed operating and installation manual(s),***
 - the warning and safety signs on the unit,***
 - the plant-specific regulations and requirements, and***
 - the national/regional regulations for safety and accident prevention.***
- Never install damaged pressure vessels or components.***



The illustrations in these instructions are for basic understanding and are preferably principle representations. Deviations from the actual design of the pressure vessel are possible depending on the design.

2.1 Intended use



WARNING

There is a risk of serious injury if the appliance is not used as intended.

This pressure vessel was built exclusively for the purpose listed below. Any other use beyond this or any conversion of the pressure vessel without written agreement with AWH is considered improper. AWH is not liable for any damage resulting from this. The risk is borne solely by the operator. The pressure vessel may only be put into operation after it has been ensured that all safety systems are functional and that the system in which this pressure vessel is installed complies with the safety requirements of all relevant European directives.

NOTE

The pressure vessel may only be installed by a qualified person.

The work described in these instructions is described in such a way that it can only be understood and carried out by a specialist.

(see section "2.6 Qualification requirements for personnel").

Containers are designed and manufactured for the reception and purification (container with filter) of liquids and gases for commercial and industrial use in compliance with the operating conditions, which must be within the intended limits.

Intended use also includes compliance with these instructions including the maintenance conditions.

Foreseeable misapplications

- The use of the pressure vessel in potentially explosive atmospheres is not permitted!
- It is prohibited to use the pressure vessel as a climbing aid!

2.2 Marking of the pressure vessel

The information in these operating instructions only applies to the pressure vessel whose type and design are indicated on the title page.

The following information is used for marking or labelling the pressure vessel:

- Year of manufacture
- for identification of the type Type/serial/ or batch identification or fabrication number;
- Essential permissible upper/lower limit values (see chapter "4 Technical data")

CE marking

The CE marking shall be affixed visibly, legibly and indelibly to the pressure vessel. If this is not possible, the CE marking shall be affixed to the packaging and the accompanying documents.

documents. The CE marking is followed by the identification number of the notified body, if required by the classification in the Pressure Equipment Directive.

2.2.1 Nameplate

The type plate is located on the pressure vessel or, if this is not possible, corresponding information can be found on the packaging or in the documentation enclosed with the pressure vessel.

The type plate provides information about

- Manufacturer's name (also registered trade name or registered trade mark) and contact details,
- Year of manufacture,
- for identification of the type Type/serial/ or batch identification or fabrication number,
- essential permissible upper/lower limit values (see chapter "4 Technical data").

Depending on the type of pressure vessel, further information must be provided which is necessary to ensure safety during installation, operation, use and, if necessary, maintenance and regular inspection.

2.3 Hazard warnings

The safety systems and safety instructions described in this manual must be observed.

All pressure components are designed according to the pressures that occur as well as the compatibility with the medium flowing through. Residual hazards can arise from damaged seals, lines or loose connections.

2.3.1 Dangers



WARNING

Pressure creates different hazards that can lead to serious injuries!

- *Only operate the pressure vessel within the permissible operating limits.*
- *Do not carry out any drilling, welding or abrasive cutting work after removing the pressure vessel.*
- *Replace seals whenever connections are renewed and according to the replacement intervals.*
- *Do not replace bolts on flanges with bolts of lower strength.*
- *Make sure that all connecting elements are complete.*

WARNING

Danger due to hydraulic energy!

When the liquid is under pressure, there is a risk of spurting liquid penetrating the skin and causing serious injury and poisoning. There is a danger from whipping hoses when they are torn off and from parts flying away.

- Only operate the pressure vessel within the permissible operating limits.*
- During commissioning, check all lines and connection points for leaks immediately after switching on the system.*
- Check print components regularly for damage and replace if necessary.*
- Wear protective work clothing, protective gloves and safety goggles when working on the pressure vessel (see section "2.7 Personal protective equipment").*
- Do not eat or drink while working.*

WARNING
Danger due to pneumatic energy!

If gases escape under pressure, there is a risk of skin and eye injuries. Escaping gas can cause eye injuries by whirling up dust or chips.

- Regularly check all lines and connections for leaks and visible damage.*
- Carefully unplug the cables.*
- Always keep the cables away from the body.*
- Wear protective work clothing, protective gloves and safety goggles when working on the pressure vessel (see section "2.7 Personal protective equipment").*

WARNING

Danger of burns from hot media!

There is a risk of burns during operation or maintenance with flow media with temperatures above +60 °C / +140 °F.

- Allow the flow medium to cool down before carrying out cleaning work.*
- Drain the pipelines before assembly/disassembly work.*
- Wear protective work clothing, protective gloves and safety goggles when working on the pressure vessel (see section "2.7 Personal protective equipment").*

2.3.2 Danger area of the pressure vessel

The area around the pressure vessel must be kept accessible to the operator.

The danger zone around the pressure vessel during set-up, maintenance and repair work must be defined by the operator.

2.3.3 Installation of spare and wear parts

Spare parts and accessories not supplied by AWH have not been tested and approved by AWH. The installation and/or use of such products can therefore, under certain circumstances, negatively change the design properties of your system. AWH accepts no liability for damage caused by the use of non-original parts and non-original accessories. Standard parts can be obtained from specialist dealers.

2.3.4 Shutdown procedure



WARNING

Dangers due to escaping fluids under high pressure!

There is a risk of serious eye and skin injuries due to escaping fluids under high pressure.

Before cleaning, maintenance or repair work (only by qualified personnel), the following shutdown procedure must be observed.

- Disconnect the higher-level system/machine from the power supply.
- Shut off the pneumatics:
 - Close the shut-off valve.
 - Check whether the system is depressurised.
 - Secure the shut-off valve against reopening.
- Shut off the media supply:
 - Relieve the pressure in the pipelines.
 - Then empty the pipelines (take special care with hazardous substances).
 - Check whether a media supply is safely prevented (if necessary, insert dummy discs).
- Allow a cooling phase for media temperatures above +60 °C / +140 °F.

2.4 Duties of the operator

The pressure vessel is used in the commercial sector. The operator is therefore subject to the legal obligations for occupational safety.

In the EEA (European Economic Area), the national transposition of the Framework Directive (89/391/EEC) on the introduction of measures to encourage improvements in the safety and health of workers at work and the associated individual directives concerning the minimum safety and health requirements for the use of work equipment by workers at work, each as amended, must be observed and complied with.

Basically, the operator in Germany has to observe the Ordinance on Industrial Safety and Health (BetrSichV).

In other countries, the relevant national guidelines, laws and country-specific regulations on occupational safety and accident prevention must be observed. The following non-exhaustive information applies in particular:

- The operator must ensure that the pressure vessel is only used for its intended purpose (see section "2.1 Intended use").
- The operator must inform himself about the locally applicable occupational health and safety regulations and, in a risk assessment, additionally determine hazards that result from the special working conditions at the place of use of the pressure vessel. He must implement these in the form of operating instructions for the operation of the pressure vessel.
- When using hazardous substances, protective measures shall be defined in accordance with the safety data sheets and hazardous substance operating instructions shall be drawn up. The personnel must be instructed in these.
This also applies to hazardous substances that can arise in the work process.
- A permanent risk assessment of the workplaces, also with regard to the temperature conditions of the medium and the place of use (fall), must be carried out. The measures must be laid down in operating instructions and the personnel must be instructed accordingly.
- The supervisors have to control the compliance with the measures from the operating instructions.
- During the entire period of use of the pressure vessel, the operator must check whether the operating instructions he has drawn up correspond to the current status of the regulations and adapt them if necessary.
- The operator must clearly regulate and define the responsibilities of the personnel (e.g. for operation, maintenance and cleaning).
- The operator may only allow sufficiently qualified and authorised personnel to work on the pressure vessel.
- The operator must ensure that all employees who handle the pressure vessel have read and understood the instructions.
Furthermore, he must demonstrably train the staff at regular intervals and inform them about hazards.
- The operator must ensure sufficient workplace lighting at the higher-level system in accordance with the locally applicable occupational health and safety regulations in order to avoid hazards due to insufficient lighting.

- The operator must provide the personnel with personal protective equipment and ensure that it is wear that it is also used (see section "2.7 Personal protective equipment").
- The operator must ensure that no persons work on the pressure vessel whose ability to react is impaired by drugs, alcohol, medication or similar.
- The operator must inform groups of persons who are not intended to handle the pressure vessel directly (e.g. groups of visitors) of impending hazards by taking appropriate measures.
- The operator is obliged to operate the pressure vessel only in perfect condition at all times.
- Wherever high pneumatic or hydraulic pressures are generated, sudden failure or damage to the lines and connections can occur. This constitutes a hazard. The operator must instruct the operating and maintenance personnel at least once a year regarding the hazards that may occur.
- The switching and safety equipment required for setting up, testing, shutting down (including emergency shutdown), operating, maintaining, cleaning and servicing must be installed and verified by the installer of the overall system.
- The operator must install fire protection equipment such as suitable hand-held fire extinguishers in the prescribed number and size in easily accessible places and instruct employees in fire protection.
- Warnings from the documentation of supplier assemblies must be observed and integrated into the workplace-related risk assessments.
- Before operating the machine/plant with the pressure vessel, the operator must ensure that the local regulations are observed during assembly and commissioning, if these are carried out by the operator himself.

NOTE

Due to different operating conditions at the operator's site, further safety measures may be required. These must be supplemented accordingly by the operator.

2.5 Safety measures (to be carried out by the operator)

- The operator must ensure that unauthorised persons (not operating and maintenance personnel) are prevented from entering the hazardous area of the system in which the pressure vessel is installed.
- Before carrying out assembly and maintenance work on the pressure vessel, the operator must drain the pipelines.
- The operator must technically design the separation of the energy sources of the higher-level system in such a way that the shutdown procedure listed in section 2.3.4 can be observed.
- This manual must be retained for future use.
It must be available at the higher-level system in which the pressure vessel is installed.
- The operator must determine and adhere to the intervals for inspections and control measures depending on the environment and media.

- The work described in the chapters Installation, Commissioning, Maintenance/Cleaning, Malfunctions and Decommissioning/Disposal may only be carried out by qualified personnel.

2.6 Qualification requirements for the staff

The pressure vessel may only be operated, maintained and repaired by persons who are qualified to do so. These persons must know the instructions and act accordingly. The respective powers of the personnel must be clearly defined.

The guidance identifies the following qualifications for different areas of activity:

Skilled worker/professional staff

A person with appropriate training, education and experience that enables them to identify risks and avoid hazards.

Due to their technical training, knowledge and experience as well as knowledge of the relevant standards and regulations, a skilled person is able to carry out work on the pressure vessel and to independently recognise and avoid possible hazards.

Only personnel with the following special knowledge may be used when working on the pressure vessel:

- Assembly/disassembly work: Industrial mechanic or comparable training, practical experience in the assembly/disassembly of fittings.

2.7 Personal protective equipment

Wear personal protective equipment when working on the pressure vessel to minimise health hazards.



Protective clothing

Protective work clothing is close-fitting work clothing with low tear resistance, with tight sleeves and no protruding parts. It is mainly used to protect against being caught by moving parts.

Do not wear rings, necklaces or other jewellery.



Safety shoes

Wear non-slip safety shoes to protect against heavy falling parts or slipping on slippery surfaces.



Protective gloves

Wear protective gloves to protect hands from friction, abrasions, punctures or deeper injuries and from touching hot surfaces or chemical substances.



Safety goggles

Wear safety goggles to protect against media escaping under high pressure or parts flying around.

**Safety helmet**

Wear a safety helmet to protect against falling or flying parts.

Personal protective equipment must be provided by the operator and must comply with the applicable requirements.

In addition, the national regulations and, if applicable, the operator's internal instructions must be observed.

3 Overview and function

3.1 Overview/structure



The schematic diagram of the pressure vessel shows examples of the optional closure variants and optional media connections.

The combination of options corresponds to a simplified representation and is not possible in practice.

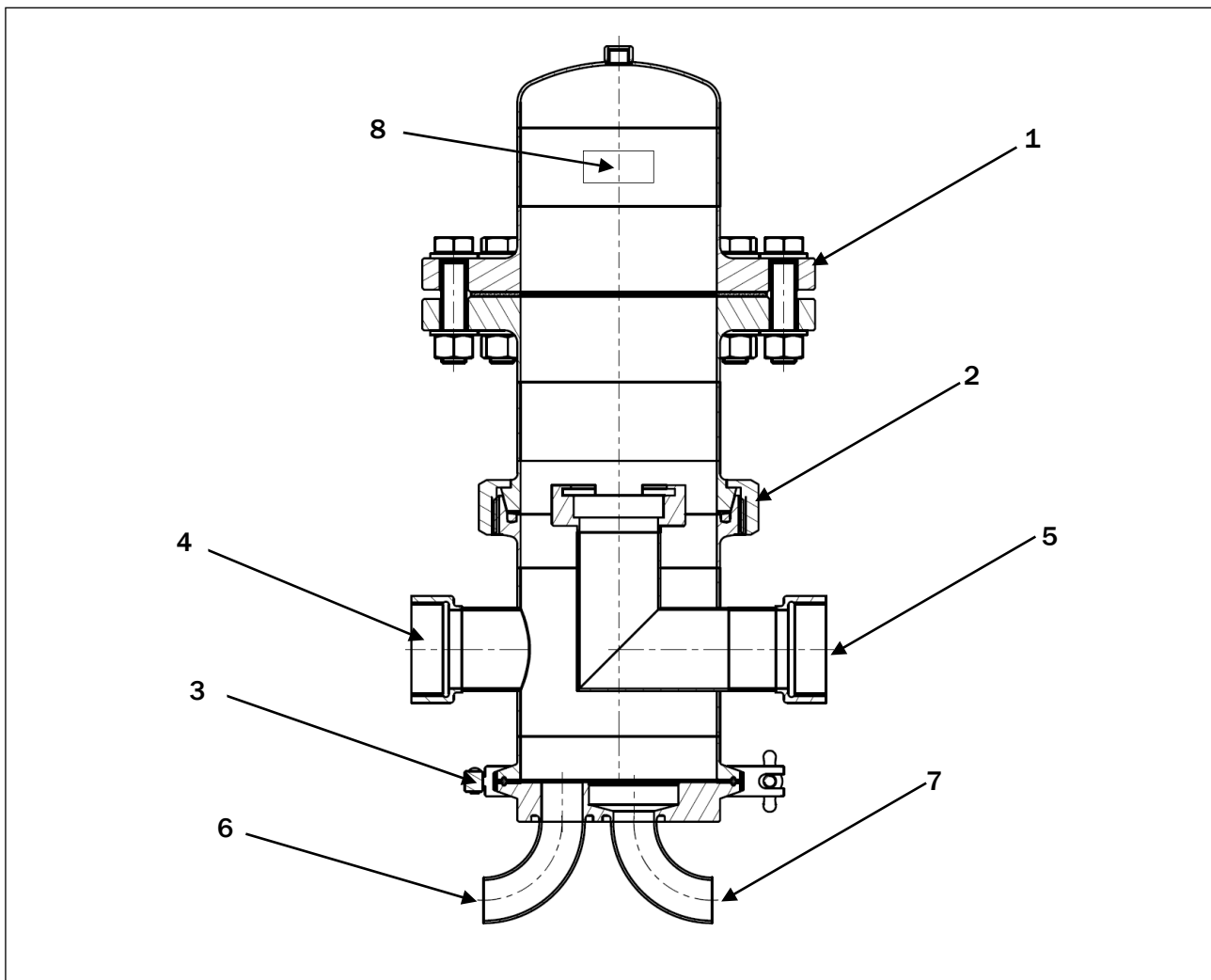

Fig. 3-1: Overview

Closure variants (optional)

- 1 Flange connection
- 2 Screw connection
- 3 Clamp connection

Media connections (optional)

- 4 Inlet nozzle Medium, gaseous
- 5 Outlet nozzle medium, gaseous
- 6 Inlet nozzle medium, liquid
- 7 Outlet nozzle medium, liquid

- 8 Nameplate

3.2 Function

According to the PED 2014/68/EU, pressure equipment is containers, pipelines, equipment parts with a safety function and pressure-maintaining equipment parts, including, if applicable, elements attached to pressure-bearing parts, such as flanges, nozzles, couplings, support elements, lifting eyes.

According to PED 2014/68/EU, a vessel is a closed component designed and constructed to contain fluids under pressure, including directly attached parts up to the device for connection to other equipment. A vessel may have several pressure compartments.

According to PED 2014/68/EU, fluids are gases, liquids and vapours as a pure phase as well as their mixtures. Fluids can contain a suspension of solids.

Pressure vessel as filtration housing

Filtration housings usually consist of a lower part that holds the filter cartridges and an upper part that serves as a dome for the cartridges.

The medium to be filtered enters the filter housing through the side inlet and flows through the filter cartridges from the outside to the inside, whereby the solid impurities are retained on the outside of the cartridge.



For detailed information on the installation of the filter cartridges and details on filtration, please refer to the description of the filter cartridges to be used in the supplier documentation.

4 Technical data



The application range of the pressure vessel must always be coordinated with the corresponding operating conditions as well as the materials in contact with the product.

The maximum continuous temperature depends on the medium.

Dimensions and weights According

to drawing no. _____.

Ambient conditions:

lower limit temperature:	+ °C/	+ °F
upper limit temperature:	+ °C/	+ °F
Humidity	% relative humidity	

Nameplate

PVA			
Model			
Model			
Ser. no.			
Ser. No.			
Chamber room	I	II	
Volume V	L		
Volume V			
Test Pressure/Date	bar		
PT Test Pressure/Date			
PT			
min./max. pressure PS	bar		
min./max. pressure PS			
min./max. temperature TS	°C		
min./max. temperature TS			
			

Fig. 4-1: Draft nameplate

Connection variants,

According to drawing no. _____.

Materials in contact with the product

Housing:

Seals:

Other materials

Connecting elements / fasteners

Lifetime

Since the manufacturer of the pressure vessel does not know the operating conditions of the operator, the service life and inspection intervals must be defined by the operator. The applicable standards, directives and laws must be observed.



For detailed information on the filter cartridges, please refer to the supplier documentation.

5 Installation

5.1 Delivery and transport



WARNING



When transporting the pressure vessel, the load may fall! Death or serious bodily injury can be the result.

- *The pressure vessel may only be transported by suitably qualified personnel and in compliance with all safety instructions.*
- *Only use approved lifting equipment and slings.*
When selecting suitable lifting equipment and load handling devices, always take into account the weight of the heaviest component.
- *Wear protective clothing, safety shoes, protective gloves and a safety helmet when working.*
- *Always secure the transport route with an additional person.*
- *Make sure that there are no persons in the travel path or under suspended loads.*
- *Do not use piping or attachments as attachment points.*
- *Always lift the pressure vessel slowly and carefully.*



CAUTION



When setting down the pressure vessel, there is a risk of minor injuries due to crushing.

- *Be especially careful when transporting the pressure vessel.*
- *Wear safety shoes and protective gloves (see section "2.7 Personal protective equipment").*

NOTE

Damage to the pressure vessel during transport

Deformations or other impairments of the surfaces and sealing surfaces may occur during transport.

- *Use suitable slings.*
- *Do not use nozzles, flanges, etc. as attachment points.*
- *Avoid point loads on the container wall.*



The detailed scope of delivery can be seen in the order confirmation.

All openings such as nozzles, flanges, etc. must be closed with suitable means and may only be removed by qualified personnel.

AWH products are carefully inspected and packed before shipment. However, damage during transport cannot be ruled out.

Incoming inspection

- Check the delivery note for completeness.
- Check for visible damage to the packaging.

Unpack

- Remove the protective caps from the pipe connections (if present).
- Remove the packaging remnants.

Damage

- Check the delivery for damage (visual inspection).

Complaints

Has the delivery been damaged during transport:

- Contact the last carrier immediately.
- Keep the packaging (for possible inspection by the carrier or for return shipment).

Packaging for return shipment

If possible, use the original packaging and packaging material. If both are no longer available, request a packaging company with specialist personnel. Consult AWH if you have any questions about packaging and securing for transport.

Interim storage

If the pressure vessel is not installed immediately after delivery, it must be stored carefully in a protected place. The pressure vessel must be stored temporarily in such a way that it is protected from cold, moisture, dirt and mechanical influences.

The pressure vessel may only be placed and stored on suitable supports (e.g. wooden saddles).

Storage conditions:

Temperature: +10 °C - +45 °C / +50 °F - +113 °F

Humidity: <60 %

5.2 Line-up



WARNING

Danger of serious injuries due to loss of stability!

- *The floor space must be level.*
- *The foundation must have the necessary load-bearing capacity.*
- *The operator is responsible for the statics of the foundation.*
- *The manufacturer's foundation instructions must be observed.*
- *Design the seat of the pressure vessel so that loosening during operation is not possible.*



WARNING

Danger of injuries due to too dense arrangement of required components and/or work equipment!

- *Have the work carried out by authorised specialist personnel only.*
- *Select the installation position and location of the pressure vessel so that the required movement space of the personnel in the working area is not restricted or obstructed.*
- *Designate required free spaces.*
- *Ensure drainage or venting possibilities.*
- *Choose supply lines that are as short as possible.*

Site



WARNING



Danger when used outdoors!

When using the pressure vessel outdoors, there is a risk of a lightning strike during a thunderstorm.

Death or serious bodily injury can be the result.

- *The pressure vessel is normally operated in an enclosed workshop and is thus protected from the risk of a lightning strike.*
- *When used outdoors, the pressure vessel must be protected from the weather by a roof.*
- *When working outdoors, stop work immediately during thunderstorms or when there is a risk of lightning.*

The installation and assembly area must be dry and clean at the time of delivery. The floor in the area of the pressure vessel to be installed must be swept clean.

The pressure vessel shall be founded in such a way that no impermissible displacements or inclinations can occur. Impermissible displacements or inclinations may be caused by the foundation itself, the dead weight of the pressure vessel, the weight of the charging material, by test equipment

When choosing the installation site, take into account the necessary operating and maintenance areas.

5.3 Assembly



WARNING

Pressure creates different hazards that can lead to serious injuries!

- Carry out the shutdown procedure of the higher-level system (see section 2.3.4).
- Flush the superordinate system before mounting the pressure vessel.
- The installation of the pressure vessel may only be carried out by a qualified person.
- Do not carry out any drilling, welding or abrasive cutting work after removing the pressure vessel.
- Replace seals whenever connections are renewed and according to the replacement intervals.
- Do not replace bolts on flanges with bolts of lower strength.
- Make sure that all connecting elements are complete.
- Comply with laws and country-specific regulations on occupational safety and accident prevention.



WARNING

Danger of serious injuries due to leaking flange and pipe connections!

- The installation of the pressure vessel may only be carried out by a specialist.
- Make sure that the flange connections or pipe connections are tight.
- After installation, tensile and compressive stresses must be excluded.



CAUTION

Danger of injury when installing the pressure vessel!

- The installation of the pressure vessel may only be carried out by a specialist.
- Wear protective work clothing, protective gloves, safety shoes, safety goggles, protective helmet when working overhead.

The pressure vessel must be connected to the intended nozzles and connections. Additional introduction of forces, bending moments or vibrations at connecting pieces through pipe connections must be avoided.

The pressure vessel is installed in accordance with the design of the piping system and the technical data of the connection variants. The installation dimensions can be found in the dimensional drawings. The required space for operation and maintenance must be ensured.

- Carry out the shutdown procedure of the higher-level system (see section 2.3.4).
- Carry out the installation of the pressure vessel in the higher-level system according to the specification of the respective customer order.
- Carry out a leak test under operating conditions.

6 Commissioning



WARNING

- Pressure creates different hazards that can lead to serious injuries!*
- In case of breakage during operation, there is a risk of injury from bursting parts.*
- *Only operate the pressure vessel within the permissible operating limits.*
 - *Have all work carried out by authorised specialist personnel only.*
 - *Do not carry out any drilling, welding or abrasive cutting work after removing the pressure vessel.*
 - *Replace seals whenever connections are renewed and according to the replacement intervals.*
 - *Do not replace bolts on flanges with bolts of lower strength.*
 - *Make sure that all connecting elements are complete.*
 - *Inspect the pressure vessel for foreign objects.*
 - *Observe the specified maintenance intervals.*
 - *Close off the danger area and keep unauthorised persons away.*
 - *Designate a responsible person.*
 - *Comply with laws and country-specific regulations on occupational safety and accident prevention.*



CAUTION

- Danger of slipping due to leakage of liquid!*
- *In the event of a defect in the system, carry out the shutdown procedure of the higher-level system (see section 2.3.4).*
 - *Remove leaked liquid immediately.*
 - *Close off the danger area and keep unauthorised persons away.*

Testing before commissioning

Before commissioning, the pressure vessel must be inspected at the installation site, whereby the country-specific regulations must be observed. In Germany, the Operational Safety Ordinance applies. The inspection must be arranged by the operator of the higher-level system.

Limiting devices

The permissible operating limits such as pressure, temperature, filling level must not be exceeded. For this reason, the pressure vessel must be equipped with the following limiting devices:

- Control facilities:

Suitable, manually operated or automatically working regulating and control devices for maintaining the

Temperature, stand switch to keep the operating conditions within the permissible minimum/maximum limits during intended operation.

– **Monitoring facilities:**

Appropriate monitoring equipment to monitor operating parameters, such as instrumentation and control (I&C), gauges, alarms, pressure, temperature and level switches, which allow appropriate manual or automatic intervention, trigger corrective action and/or provide shutdown and lockout to maintain the pressure vessel within allowable operating limits.

– **Safety devices:**

Appropriate safety devices such as safety valves, bursting disc safety devices, buckling bar devices, etc. or safety-related M&C devices which, as a final hazard prevention measure, ensure that the permissible operating limits are not exceeded.

Start-up

The pressure vessel must be started up in such a way that no impermissible stress increases result from the temperature rise or pressure rise.

The max. permissible temperature rise is 50 °C/h.

During start-up operation, the pressure vessel must be constantly observed and checked for possible leaks.

Periodic inspection

If the pressure vessel is installed in Germany, the operator must have it inspected at regular intervals by approved inspection bodies in accordance with the Operational Safety Ordinance to ensure that it is in proper condition. In other countries of installation, other applicable national regulations must be observed.

7 Maintenance/Cleaning



WARNING

Risk of serious injury due to improper maintenance and cleaning!

There is a risk of poisoning or chemical burns if hazardous, toxic or other dangerous media are used!

- *The work may only be carried out by a specialist.*
- *Always follow the shutdown procedure before carrying out any cleaning, maintenance or repair work (see section 2.3.4).*
- *Wear protective work clothing, protective gloves and safety goggles when working (see section "2.7 Personal protective equipment").*
- *Check the pressure vessel regularly for leaks.*
- *Clean the pressure vessel from residual media.*
- *Inspect the pressure vessel for foreign bodies and remove foreign bodies.*
- *Comply with laws and country-specific regulations on occupational safety and accident prevention.*



WARNING

Danger due to hydraulic energy!

When the liquid is under pressure, there is a danger of spurting liquid penetrating the skin and causing serious injury and poisoning. There is a danger from whipping hoses when they are torn off and from parts flying away.

- *Only operate the pressure vessel within the permissible operating limits.*
- *During commissioning, check all lines and connection points for leaks immediately after switching on the system.*
- *Check print components regularly for damage and replace if necessary.*
- *Wear protective work clothing, protective gloves and safety goggles when working on the pressure vessel (see section "2.7 Personal protective equipment").*
- *Do not eat or drink while working.*

WARNING

Danger due to pneumatic energy!

If gases escape under pressure, there is a risk of skin and eye injuries.

Escaping gas can cause eye injuries by whirling up dust or chips.

- *Regularly check all lines and connections for leaks and visible damage.*
- *Carefully disconnect the cables.*
- *Always keep the cables away from the body.*
- *Wear protective work clothing, protective gloves and safety goggles when working on the pressure vessel (see section "2.7 Personal protective equipment").*

WARNING

Danger of burns from hot media!

The danger of burns exists with flow media with temperatures above +60 °C / +140 °F.

- *Let the flow medium cool down before starting work.*
- *Drain the pipelines before cleaning, maintenance or repair work.*
- *Wear protective work clothing, protective gloves and safety goggles when working (see section "2.7 Personal protective equipment").*

CAUTION

Contact with greases and detergents may cause skin irritation.

- *Proceed with particular caution during the work.*
- *Wear protective gloves, safety goggles, work clothes and safety shoes when working (see section "2.7 Personal protective equipment").*



For detailed information on maintenance and cleaning of the filter cartridges, please refer to the supplier documentation.

7.1 Closing and opening the pressure vessel

- The pressure vessel must be closed in such a way that all closures provided by design are used as intended.
- Sealing surfaces must be clean and undamaged.
- Defective closing elements, e.g. worn, cracked and bent screws, broken or otherwise damaged nuts, bent clips or brackets, damaged seals, must no longer be used and must be replaced by similar ones.

- Screw plugs may only be tightened carefully and evenly as far as is necessary for sealing. The specified tightening torques must be observed. On the pressurised
-

When the pressure vessel is under pressure, screw plugs may only be tightened by qualified personnel taking special precautions. Screw plugs must not be loosened on pressurised pressure vessels.

- Be sure to follow the shutdown procedure before opening closures and inspection ports (see section 2.3.4).

Walk-in pressure vessels

- When lifting the cover, use only approved lifting equipment and slings designed for the weight.
- When transporting the cover, no persons may be in the immediate danger zone, especially under suspended loads.

7.2 Cleaning/maintenance intervals

To ensure trouble-free operation of the pressure vessel, it is essential that it is cleaned and maintained at regular intervals.

- Carry out a daily visual inspection for mechanical damage, dirt deposits and unusual noises on the entire pressure vessel.
- Set the cleaning intervals depending on the operating environment and the flow medium.
- Set inspection intervals for seals depending on the operating environment and the flow medium.
- The pressure vessel is subject to vibrations during operation which can cause screw and clamp connections to loosen. To prevent damage, check the pressure vessel for loose connections at regular intervals (recommended interval for single-shift operation 3 months).
- Report any damage to the supervisor immediately.

7.3 Notes on cleaning



WARNING

Risk of injury due to improper handling of cleaning agents!

- *Store the cleaning agents according to the valid safety guidelines.*
- *When handling the cleaning agents, observe the safety instructions in the cleaning agent manufacturer's data sheet.*
- *Always wear protective gloves and goggles when cleaning (see section "2.7 Personal protective equipment").*
- *Make sure that you do not touch the pressure vessel or the piping during the processing of warm media or during the sterilisation process.*

Cleaning intervals, cleaning agents and type of cleaning are to be adapted to the flow medium and determined by the operator according to specification.

Note the following:

- Use only clean and chlorine-free water.
- Dose carefully to avoid over-concentration of the detergent.
- After cleaning, rinse with plenty of clean water.

Sterilisation

For sterilisation temperature and duration, the seal materials must be taken into account.

7.4 Spare parts stock

When requesting spare parts, please always state the type of pressure vessel. The following information is important for all spare parts requests or queries:

- Nominal width
- Sealing material
- Housing material
- Connection type
- Accessories

Specific spare parts (see parts list)

Pos.	Designation	Item no.	Note

8 Disruptions

8.1 Safety instructions



WARNING

Danger of serious injuries due to improperly performed repair work!

There is a risk of poisoning or chemical burns if hazardous, toxic or other dangerous media are used!

- *Have troubleshooting work carried out by qualified personnel only.*
- *Be sure to follow the shutdown procedure before carrying out any repair work (see section 2.3.4).*
- *Wear protective work clothing, protective gloves and safety goggles when working (see section "2.7 Personal protective equipment").*
- *Comply with laws and country-specific regulations on occupational safety and accident prevention.*



WARNING

Pressure creates different hazards that can lead to serious injuries!

- *Only operate the pressure vessel within the permissible operating limits.*
- *Have troubleshooting work carried out by qualified personnel only.*
- *Wear protective work clothing, protective gloves and safety goggles when working (see section "2.7 Personal protective equipment").*
- *Do not replace bolts on flanges with bolts of lower strength.*
- *Make sure that all connecting elements are complete.*



WARNING

Danger of burns from hot media!

The risk of burns exists with flow media with temperatures above +60 °C / +140 °F.

- *Let the flow medium cool down before starting work.*
- *Drain the pipelines before carrying out repair work.*
- *Wear protective work clothing, protective gloves and safety goggles when working (see section "2.7 Personal protective equipment").*

WARNING
Danger due to hydraulic energy!

When the liquid is under pressure, there is a danger of spurting liquid penetrating the skin and causing serious injury and poisoning. There is a danger from whipping hoses when they are torn off and from parts flying away.

- Only operate the pressure vessel within the permissible operating limits.*
- During commissioning, check all lines and connection points for leaks immediately after switching on the system.*
- Check print components regularly for damage and replace if necessary.*
- Wear protective work clothing, protective gloves and safety goggles when working on the pressure vessel (see section "2.7 Personal protective equipment").*
- Do not eat or drink while working.*

WARNING
Danger due to pneumatic energy!

If gases escape under pressure, there is a risk of skin and eye injuries.

Escaping gas can cause eye injuries by whirling up dust or chips.

- Regularly check all lines and connections for leaks and visible damage.*
- Carefully unplug the cables.*
- Always keep the cables away from the body.*
- Wear protective work clothing, protective gloves and safety goggles when working on the pressure vessel (see section "2.7 Personal protective equipment").*

Repair work that may affect the safety of the pressure vessel as well as measures that change the material properties, e.g. by welding, cold and hot deformation, may only be carried out in accordance with the national regulations of the country of installation.

8.2 Behaviour in an emergency

- Trigger the emergency stop function on the higher-level system (e.g. by pressing the emergency stop switch).
- Lock the media feed.



9 Decommissioning / disposal

- Carry out the shutdown procedure for the higher-level system (see section 2.3.4).



WARNING

Danger of serious injuries due to improper disassembly!

There is a risk of poisoning or chemical burns if hazardous, toxic or other dangerous media are used!

- ***Dismantling work may only be carried out by qualified personnel.***
- ***Before disassembly work, be sure to follow the shutdown procedure (see section 2.3.4).***
- ***Wear protective work clothing, protective gloves and safety goggles when working (see section "2.7 Personal protective equipment").***
- ***Collect leaking liquids and dispose of them in accordance with the applicable regulations.***
- ***Comply with laws and country-specific regulations on occupational safety and accident prevention.***



WARNING

Danger due to hydraulic energy!

When the liquid is under pressure, there is a danger of spurting liquid penetrating the skin and causing serious injury and poisoning. There is a danger from whipping hoses when they are torn off and from parts flying away.

- ***Only operate the pressure vessel within the permissible operating limits.***
- ***During commissioning, check all lines and connection points for leaks immediately after switching on the system.***
- ***Check print components regularly for damage and replace if necessary.***
- ***Wear protective work clothing, protective gloves and safety goggles when working on the pressure vessel (see section "2.7 Personal protective equipment").***
- ***Do not eat or drink while working.***

WARNING

Danger due to pneumatic energy!

If gases escape under pressure, there is a risk of skin and eye injuries.

Escaping gas can cause eye injuries by whirling up dust or chips.

- Regularly check all lines and connections for leaks and visible damage.
- Carefully unplug the cables.
- Always keep the cables away from the body.
- Wear protective work clothing, protective gloves and safety goggles when working on the pressure vessel (see section "2.7 Personal protective equipment").

WARNING

Danger of burns from hot media!

The risk of burns exists with flow media with temperatures above +60 °C / +140 °F.

- Let the flow medium cool down before starting work.
- Drain the pipelines before disassembly work.
- Wear protective work clothing, protective gloves and safety goggles when working (see section "2.7 Personal protective equipment").

Departure

The pressure vessel must be shut down in such a way that no inadmissible stress increases result from the temperature drop or pressure drop.

The maximum permissible temperature drop is 50 °C/h.

9.1 Disposal

CAUTION

Risk of injury from harmful liquids

During disposal, there is a risk of injury from contact with harmful liquids.

- Wear the appropriate personal protective equipment (e.g. safety goggles, protective gloves, see section "2.7 Personal protective equipment").

NOTE



Danger of environmental damage in case of improper disposal!

- ***The pressure vessel is mainly made of stainless steel (except for seals) and must be disposed of in accordance with the applicable local environmental regulations.***
- ***Oils and cleaning agents must NOT be allowed to enter groundwater, water bodies or sewers and must be disposed of in accordance with local regulations and in compliance with the instructions in the safety data sheets of the cleaning agent manufacturers.***
- ***Contaminated cleaning tools (brushes, rags, etc.) must be disposed of according to the manufacturer's instructions.***
- ***Packaging material must be disposed of in an environmentally friendly manner and recycled.***

10 Explanations

Declarations on pressure vessels within the meaning of the Pressure Equipment Directive 2014/68/EU

The pressure vessels covered by Article 4, paragraph 3 of the Pressure Equipment Directive 2014/68/EU do not receive an EU declaration of conformity and a CE mark in the sense of this Directive.

The pressure vessels falling within the scope of Directive 2014/68/EU shall be provided with an EU declaration of conformity and a CE mark in accordance with this Directive.

The pressure vessel shall be subjected to a conformity assessment procedure, to be chosen by the manufacturer, according to the category to which it belongs.

A conformity assessment procedure with module A (internal production control) can be carried out for containers to be classified in category I.

In the case of make-to-order production, the individual inspection by the Notified Body expert is largely included in modules G, B1+F and B+F.

A conformity assessment procedure with the modules or module combinations G, B1+F and B+F can be carried out for containers which are to be classified in categories III (B1+F) or IV (G and B+F).

The manufacturer may opt for a conformity assessment procedure intended for a higher category. (Module IV is the highest module category).

Index

A

List of Figures.....	II
Departure.....	32
Abbreviations	3
Dimensions	16
Shutdown procedure.....	9
Approach.....	24
Disconnect the system from the power supply	9
Connection variants	16
Line-up	20
Site.....	20
Unpacking	19
Decommissioning	31

B

Complaints	19
Limiting devices	23
Damage	19
Intended use	6
Operator obligations.....	10

D

Means of representation	2
Compressed air	9

E

Installation position	20
Incoming inspection.....	19
Disposal.....	31, 32
Explanations	34
Spare/wear parts	9, 28

F

Specialist	12
Specialist staff	12

G

Warranty	4
Danger from pressure	7, 21, 23, 29

Danger area of thepressure vessel8
Hazard statements7
 Hazardous flow media25....., 29, 31
Hazardous substances9, 10
 Warranty4

H

.....Liability4
 Hotmedia8,26, 29, 32
 Hydraulicenergy8,25, 30, 31

I

.....Commissioning23
 Contentl
 Installation18

K

Marking of thepressure vessel6

.....Storage conditions19
 Lifespan 17
 Delivery 18

M

.....Assembl y21

N

.....Emergen cy30

P

.....Personn el qualifications12
 personal
protectiv e equipment12
 Pneumatic energy8,26, 30, 32
 Exam
 before
commiss ioning23
recurring 23

Q

..... Cr
ushing hazard18

R

..... Cleani
ng25, 27
Cleaning and maintenance intervals27

..... Re
turn shipping19

S

Closing/opening the
..... pr
essure vessel26

..... S
ecurity5

..... Se
curity measures11

..... St
erilisation28

.....Disru
ptions5, 29

..... S
ymbols3

T

Technical data16
Materialsin contact with
the product17.....

..... Transport18
..... Nameplate16

U

Overview

..... Structure14
..... Environmental
conditions16

W

..... Maintenance2
5

Z

..... Interim
storage19

pure! GmbH

Konrad-Zuse-Straße 5

D-65549 Limburg

Phone +49 6431 49612 40

Fax +49 6431 49612 41

E-Mail support@pure-gmbh.com

Internet <http://www.pure-gmbh.com>