

MXLE

Low energy heatless dryers



ENGINEERING YOUR SUCCESS.

Compressed air contamination is a real problem for industry

In today's modern production facilities, the use of compressed air is often pivotal to manufacturing processes. Irrespective of whether the compressed air comes into direct contact with the product or is used to automate a process, provide motive power, or even to generate other gases on-site, a clean, dry, reliable compressed air supply is essential to maintain efficient and cost effective production.

Parker provides complete compressed air treatment solutions to suit every industry, application & budget.

The benefits of using Parker compressed air treatment solutions:

- **Plant Reliability** - trouble free operation from equipment and processes using compressed air
- **Clean Dry Air** available for all applications
- **No contamination** of products / processes / equipment
- **Low Maintenance Costs** – Reduce or eliminate unexpected / unplanned plant maintenance for better budget control
- **Lower plant energy consumption**
- **Lower plant environmental impact**
- **Legislation compliance** – e.g. assist in complying with hygiene legislation in the Food, Beverage & Pharmaceutical industries

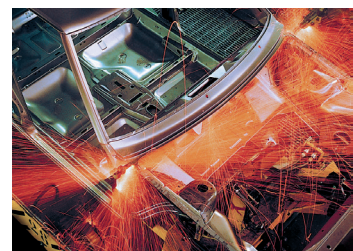

Compressed air dryers – The heart of the compressed air treatment solution

At the heart of any compressed air treatment solution is the dryer, it's purpose, to remove water vapour, stop condensation, corrosion and in the case of adsorption dryers, inhibit the growth of micro-organisms.

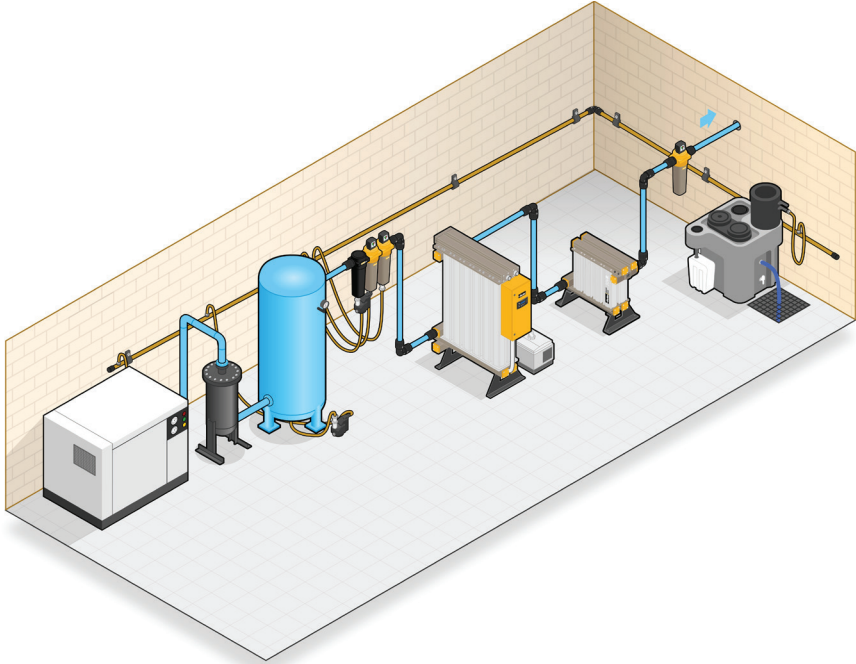

Heatless adsorption dryers (also known as PSA dryers) are the simplest type of adsorption dryer available and have long been the dryer of choice for many industries and applications. They are simple, reliable and cost effective and for small to medium flow systems, often

the only viable technology available. Additionally, modular heatless dryers such as MXLE provide an even more reliable, smaller, more compact & lightweight dryer which can be installed in both the compressor room or at the point of use.

Benefits of Heatless Adsorption Dryers

- Industry proven design
- Suitable for all industries and applications - some adsorption dryer regeneration methods prevent their use in certain industries / applications
- Lower capital investment compared to other adsorption dryer regeneration methods
- Reduced complexity compared to other adsorption dryer regeneration methods
- Robust & reliable
- Uses clean, dry compressed air for regeneration making them suitable for all industries and applications
- Lower maintenance costs compared to other adsorption dryer regeneration methods
- No heat / heaters / heat related issues



RELIABILITY



QUALITY



EFFICIENCY



Improving manufacturing efficiency

Every manufacturing organisation strives to improve its operational efficiency, especially in terms of energy consumption and environmental impact.

Heatless adsorption dryers use clean, dry process air for regeneration, but in real terms, this means that not all of the compressed air generated is available for manufacturing processes.

Generating compressed air uses electrical energy, so although heatless adsorption dryers have many benefits, the energy costs associated with this

type of dryer may be higher when compared to other types of adsorption dryers with different regeneration methods.



INTRODUCING

MXLE

Low Energy Heatless Adsorption Dryers

MXLE has been specifically designed to provide all of the benefits of a traditional MX heatless adsorption dryer with the additional benefits of increased compressed air available for plant use, lower energy costs and lower environmental impact.

Dryer Selection
Dryers should not be selected upon energy costs alone, but on delivered air quality, their suitability for the industry & application in which they are to operate, reliability and total cost of ownership.



MXLE

Features & Benefits

- **Complete clean dry air solution with guaranteed air quality**
 - Includes Pre & Post Filtration
 - Delivered air quality in accordance with ISO8573-1
 - 3rd Party validated performance on both dryer and pre / post filtration
 - Dryer tested in accordance with ISO7183
 - Filters tested in accordance with ISO12500-1 / ISO8573-4
- **Modular construction**
 - Smaller, more compact & lightweight than traditional Twin Tower dryers
 - Fully expandable as your system grows
 - Existing MX dryers can be upgraded to extend life of existing capital equipment and lower capital expenditure
- **Low energy heatless technology**
 - 17% more air available for use than a comparative heatless dryer
 - On average, 60% lower energy consumption than a comparative heatless dryer & 39% lower energy consumption than a comparative heat regenerative dryer
- **Energy Management System fitted as standard for additional savings**
- **Suitable for all industrial applications**
- **Ideally suited for food, beverage and pharmaceutical industries & applications**
 - Uses clean dry process air for regeneration (no contamination of adsorption bed)
 - Materials of Construction FDA Title 21 Compliant and EC1935-2004 exempt
- **Heatless fall back mode for extra security**
 - Extra security – should a fault occur with the vacuum pump, dryer can be operated in full heatless mode to keep plant operational
- **Lower total cost of ownership**
 - Low running costs
 - Shorter maintenance times & extended preventative maintenance periods
 - Lower maintenance costs compared to other types of low energy dryer
- **Lifetime warranty available**

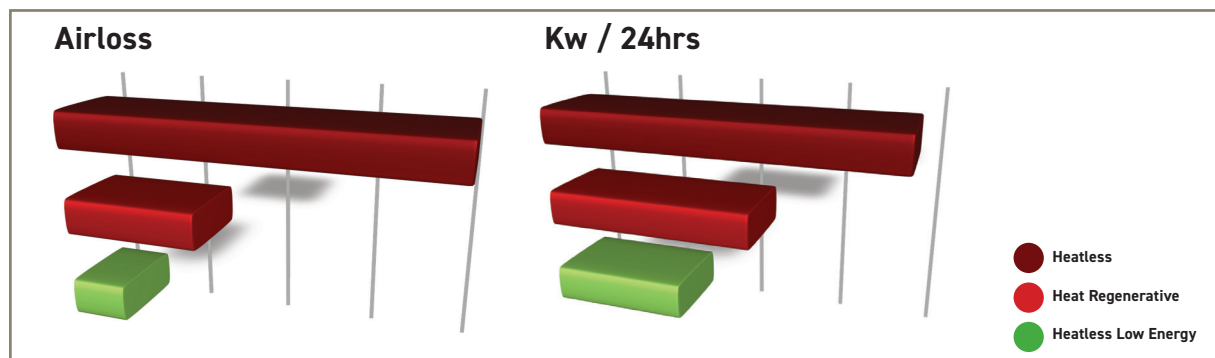

MXLE

Product selection

	Model	Pipe Size	Flowrates			
			L/s	m ³ /min	m ³ /hr	cfm
Single Bank	MXLE 102C	2"	113	6.81	408	240
	MXLE 103C	2"	170	10.22	612	360
	MXLE 103	2"	213	12.78	765	450
	MXLE 104	2½"	283	17.03	1020	600
	MXLE 105	2½"	354	21	1275	750
	MXLE 106	2½"	425	26	1530	900
	MXLE 107	2½"	496	30	1785	1050
	MXLE 108	2½"	567	34	2040	1200



Stated flows are for operation at 7 bar g (100 psi g) with reference to 20 °C, 1 bar a, 0 % relative water vapour pressure.
For flows at other pressures apply the correction factors shown.

Dryer performance

Dryer Models	Dewpoint (Standard)		ISO8573-1:2010 Classification (standard)	Dewpoint (Option 1)		ISO8573-1:2010 Classification (Option 1)	Dewpoint (Option 2)		ISO8573-1:2010 Classification (Option 2)
	°C	°F		°C	°F		°C	°F	
MXLE	-40	-40	Class 2:2:2	-70	-100	Class 2:1:2	-20	-4	Class 2:3:2

* ISO8573-1 Classifications when used with included Parker OIL-X pre / post filtration

Technical data

Dryer Models	Min Operating Pressure		Max Operating Pressure		Min Operating Temp		Max Operating Temp		Max Ambient Temp		Electrical supply (standard)	Electrical supply (optional)	Thread Connections	Noise Level dB (A)
	bar g	psi g	bar g	psi g	°C	°F	°C	°F	°C	°F				
MXLE	5	58	13	190	5	41	50	122	55	131	400V +/- 10% 3PH 50Hz 460V +/- 4.35% 3PH 60Hz	N/A	BSPP	<75

Model		MXLE102c	MXLE103c	MXLE103	MXLE104	MXLE105	MXLE106	MXLE107	MXLE108
Vacuum Pump kW	50Hz	3	3	4	5.5	5.5	8	9.5	9.5
	60Hz	4.8	4.8	6.5	9	9	13	15.5	15.5

Correction factors

Temperature Correction Factor CFT										
Maximum Inlet Temperature	°C	25	30	35	40	45	50			
	°F	77	86	95	104	113	122			
	CFT	1.00	1.00	1.00	1.04	1.14	1.37			
Pressure Correction Factor CFP										
Minimum Inlet Pressure	bar g	5	6	7	8	9	10	11	12	13
	psi g	73	87	100	116	131	145	160	174	189
	CFP	1.33	1.14	1.00	0.89	0.80	0.73	0.67	0.62	0.57
Dewpoint Correction Factor CFD		Option 2	Standard	Option 1						
Required Dewpoint	PDP °C	-20	-40	-70						
	PDP °F	-4	-40	-100						
	CFD	0.91	1.00	1.43						

For correct operation, compressed air dryers must be sized for the minimum inlet pressure, maximum inlet temperature and maximum flow rate at the point of installation.

To select a dryer, first calculate the MDC (Minimum Drying Capacity) using the formula below then select a dryer from the flow rate table above, with a flow rate equal to or greater than the MDC.

Minimum Drying Capacity =
System Flow x CFT x CFP x CFD

Dryer coding example

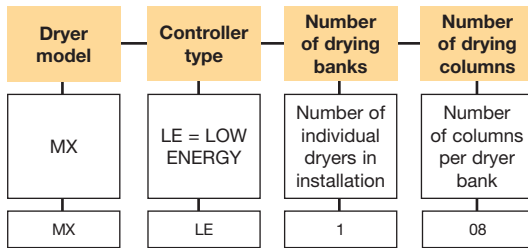

Part numbers

Dryer Part Numbers		Vacuum Pump Part Numbers 50Hz	Vacuum Pump Part Numbers 60Hz	Dryer Upgrade Kits Part Numbers
-20°C /-40°C PDP	-70°C PDP			
MXLE102C	MXLE102C-70	MXLEP2C-E	MXLEP2C-E-60	MXLEK2C
MXLE103C	MXLE103C-70	MXLEP3C-E	MXLEP3C-E-60	MXLEK3C
MXLE103	MXLE103-70	MXLEP3-E	MXLEP3-E-60	MXLEK3
MXLE104	MXLE104-70	MXLEP4-E	MXLEP4-E-60	MXLEK4
MXLE105	MXLE105-70	MXLEP5-E	MXLEP5-E-60	MXLEK5
MXLE106	MXLE106-70	MXLEP6-E	MXLEP6-E-60	MXLEK6
MXLE107	MXLE107-70	MXLEP7-E	MXLEP7-E-60	MXLEK7
MXLE108	MXLE108-70	MXLEP8-E	MXLEP8-E-60	MXLEK8

Weights and dimensions

Model	Pipe Size	Dryer Dimensions							
		Height (H)		Width (W)		Depth (D)		Weight	
		mm	ins	mm	ins	mm	ins	kg	lbs
MXLE102c	2"	1647	64.8	793.5	31.5	550	21.7	265	583
MXLE103c	2"	1647	64.8	962.5	37.9	550	21.7	346	761
MXLE103	2"	1892	74.5	962.5	37.9	550	21.7	385	847
MXLE104	2½"	1892	74.5	1131.5	44.6	550	21.7	480	1056
MXLE105	2½"	1892	74.5	1300.5	51.2	550	21.7	573	1261
MXLE106	2½"	1892	74.5	1469.5	57.9	550	21.7	667	1467
MXLE107	2½"	1892	74.5	1641.5	64.6	550	21.7	761	1674
MXLE108	2½"	1892	74.5	1807.5	71.2	550	21.7	855	1881

Model	Vacuum Pump Dimensions							
	Height (H)		Width (W)		Depth (D)		Weight	
	mm	ins	mm	ins	mm	ins	kg	lbs
MXLE102c	400	15.75	933	36.73	523	20.59	89	196
MXLE103c	400	15.75	933	36.73	523	20.59	89	196
MXLE103	400	15.75	933	36.73	523	20.59	194	428
MXLE104	400	15.75	933	36.73	523	20.59	184	406
MXLE105	400	15.75	933	36.73	523	20.59	184	406
MXLE106	1304	51.34	1100	43.31	560	22.05	420	926
MXLE107	1304	51.34	1100	43.31	560	22.05	390	860
MXLE108	1304	51.34	1100	43.31	560	22.05	390	860

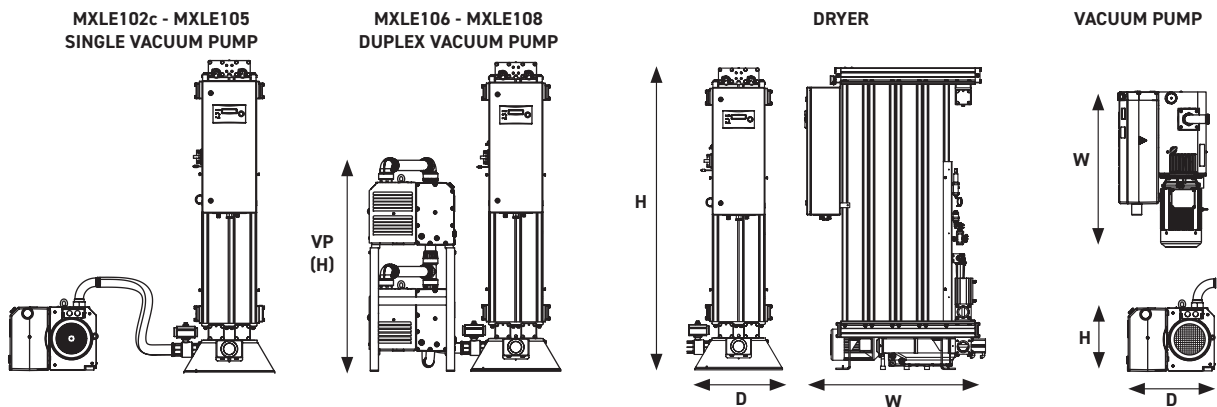

Included filtration

For Dryer Model	Filter Pipe Size BSPP	Inlet General Purpose Pre-filter	Inlet High Efficiency Filter	Outlet Dry Particulate Filter
MXLE 102C	2"	AOP040HGFX	AAP040HGFX	AOP040HGMX
MXLE 103C	2"	AOP040HGFX	AAP040HGFX	AOP040HGMX
MXLE 103	2"	AOP045HGFX	AAP045HGFX	AOP045HGMX
MXLE 104	2½"	AOP0045IGFX	AAP045IGFX	AOP045IGMX
MXLE 105	2½"	AOP050IGFX	AAP050IGFX	AOP050IGMX
MXLE 106	2½"	AOP050IGFX	AAP050IGFX	AOP050IGMX
MXLE 107	2½"	AOP055IGFX	AAP055IGFX	AOP055IGMX
MXLE 108	2½"	AOP055IGFX	AAP055IGFX	AOP055IGMX

Parker Worldwide

Europe, Middle East, Africa

AE – United Arab Emirates,
Dubai

Tel: +971 4 8127100
parker.me@parker.com

AT – Austria, St. Florian
Tel: +43 (0)7224 66201
parker.austria@parker.com

AZ – Azerbaijan, Baku
Tel: +994 50 2233 458
parker.azerbaijan@parker.com

BE/NL/LU – Benelux,
Hendrik Ido Ambacht
Tel: +31 (0)541 585 000
parker.nl@parker.com

BG – Bulgaria, Sofia
Tel: +359 2 980 1344
parker.bulgaria@parker.com

BY – Belarus, Minsk
Tel: +48 (0)22 573 24 00
parker.poland@parker.com

CH – Switzerland, Etoy
Tel: +41 (0)21 821 87 00
parker.switzerland@parker.com

CZ – Czech Republic, Klecany
Tel: +420 284 083 111
parker.czechrepublic@parker.com

DE – Germany, Kaarst
Tel: +49 (0)2131 4016 0
parker.germany@parker.com

DK – Denmark, Ballerup
Tel: +45 43 56 04 00
parker.denmark@parker.com

ES – Spain, Madrid
Tel: +34 902 330 001
parker.spain@parker.com

FI – Finland, Vantaa
Tel: +358 (0)20 753 2500
parker.finland@parker.com

FR – France, Contamine s/Arve
Tel: +33 (0)4 50 25 80 25
parker.france@parker.com

GR – Greece, Piraeus
Tel: +30 210 933 6450
parker.greece@parker.com

HU – Hungary, Budaörs
Tel: +36 23 885 470
parker.hungary@parker.com

IE – Ireland, Dublin
Tel: +353 (0)1 466 6370
parker.ireland@parker.com

IL – Israel
Tel: +39 02 45 19 21
parker.israel@parker.com

IT – Italy, Corsico (MI)
Tel: +39 02 45 19 21
parker.italy@parker.com

KZ – Kazakhstan, Almaty
Tel: +7 7273 561 000
parker.easteurope@parker.com

NO – Norway, Asker
Tel: +47 66 75 34 00
parker.norway@parker.com

PL – Poland, Warsaw
Tel: +48 (0)22 573 24 00
parker.poland@parker.com

PT – Portugal
Tel: +351 22 999 7360
parker.portugal@parker.com

RO – Romania, Bucharest
Tel: +40 21 252 1382
parker.romania@parker.com

RU – Russia, Moscow
Tel: +7 495 645-2156
parker.russia@parker.com

SE – Sweden, Spånga
Tel: +46 (0)8 59 79 50 00
parker.sweden@parker.com

SK – Slovakia, Banská Bystrica
Tel: +421 484 162 252
parker.slovakia@parker.com

SL – Slovenia, Novo Mesto
Tel: +386 7 337 6650
parker.slovenia@parker.com

TR – Turkey, Istanbul
Tel: +90 216 4997081
parker.turkey@parker.com

UA – Ukraine, Kiev
Tel: +48 (0)22 573 24 00
parker.poland@parker.com

UK – United Kingdom, Warwick
Tel: +44 (0)1926 317 878
parker.uk@parker.com

ZA – South Africa, Kempton Park
Tel: +27 (0)11 961 0700
parker.southafrica@parker.com

North America

CA – Canada, Milton, Ontario
Tel: +1 905 693 3000

US – USA, Cleveland
Tel: +1 216 896 3000

Asia Pacific

AU – Australia, Castle Hill
Tel: +61 (0)2-9634 7777

CN – China, Shanghai
Tel: +86 21 2899 5000

HK – Hong Kong
Tel: +852 2428 8008

IN – India, Mumbai
Tel: +91 22 6513 7081-85

JP – Japan, Tokyo
Tel: +81 (0)3 6408 3901

KR – South Korea, Seoul
Tel: +82 2 559 0400

MY – Malaysia, Shah Alam
Tel: +60 3 7849 0800

NZ – New Zealand, Mt Wellington
Tel: +64 9 574 1744

SG – Singapore
Tel: +65 6887 6300

TH – Thailand, Bangkok
Tel: +662 186 7000

TW – Taiwan, Taipei
Tel: +886 2 2298 8987

South America

AR – Argentina, Buenos Aires
Tel: +54 3327 44 4129

BR – Brazil, Sao Jose dos Campos
Tel: +55 800 727 5374

CL – Chile, Santiago
Tel: +56 2 623 1216

MX – Mexico, Toluca
Tel: +52 72 2275 4200



EMEA Product Information Centre

Free phone: 00 800 27 27 5374

(from AT, BE, CH, CZ, DE, DK, EE, ES, FI, FR, IE, IL, IS, IT, LU, MT, NL, NO, PL, PT, RU, SE, SK, UK, ZA)

US Product Information Centre

Toll-free number: 1-800-27 27 537

www.parker.com/gsf