

HDK-MT 15/100 - 70/100

High-pressure dryer for compressed air up to 100 bar



Short description

HDK-MT series Parker Zander high-pressure dryers are designed to be ideal for high-pressure ranges of compressed air and gaseous Nitrogen up to 100 bar.

The patent-protected concept of HDK-MT series unique in its compact design combines the vibration-resistant, torsion-rigid dryer unit made of high precise vessel pipes and valve blocks with the pre-stressed filling of highly active desiccant beads.

The dryers of HDK-MT series including the mounted filters of GH series with their tie-rod fixed filter elements offer hardly any target for torsional forces and abrasion, and thus provide the safe, reliable, and robust operation under pressure variations and constant vibration predominant for discontinuous operation in the high-pressure ranges.

The particular choice of corrosion-resistant materials like hard-coated Aluminium of the valve blocks, seamless vessels and fittings made of stainless steel make the dryers of HDK-MT series ideally suited for harsh environments.



In contrast to traditional designs the dryer of HDK-MT series are technically leakage-free, a side effect of their compact, high-precise design with only few fittings – only for the mounted pre- and afterfilter of GH series – and thereby offer an enormous potential for energy savings and efficiency maximisation. In line with the need-based dew-point dependent control as well as with the need-based setting of the regeneration

gas flow the unnecessary and expensive loss of already high-compressed air and the ongoing startup of the compressor will be prevented in this way.

The compact and robust design of the dryers ideally suits for built-in installations in tight spaces as typical for compressor skids as well as installations on ship, on platform, and in container sites.

Scope of supply

- Ready-to-install high-pressure adsorption dryer including dew-point control and mounted pre- and afterfilter.
- Optionally available with start-up device as well as further filter equipment mounted ex-works.

Product Specification

High-pressure dryer series HDK-MT up to 100 bar

Order and performance information for pressure dew-points of -25/-40 °C

Model	Order no.	Performance ¹	Port size ²	Prefilter	Afterfilter
HDK-MT 15/100	H15/100D2-G230MT	120	G1/2	GH7/100XP	GH7/100ZP/VV
HDK-MT 20/100	H20/100D2-G230MT	180	G1/2	GH7/100XP	GH7/100ZP/VV
HDK-MT 25/100	H25/100D2-G230MT	240	G1/2	GH7/100XP	GH7/100ZP/VV
HDK-MT 30/100	H30/100D2-G230MT	300	G1/2	GH7/100XP	GH7/100ZP/VV
HDK-MT 40/100	H40/100D2-G230MT	400	G3/4	GH9/100XP	GH9/100ZP/VV
HDK-MT 50/100	H50/100D2-G230MT	520	G3/4	GH9/100XP	GH9/100ZP/VV
HDK-MT 70/100	H70/100D2-G230MT	650	G3/4	GH9/100XP	GH9/100ZP/VV

¹) Maximum flow rate in m³/h referred to 1 bara and 20 °C, subsequently compressed to 100 bar_e and a compressed air inlet temperature of 35 °C. With deviant minimum operating pressure, compressed air inlet temperature the actual flow rate must be multiplied by the respective correction factor CFP and CFT (see below) in order to determine the necessary nominal flow rate and thus the dryer model required.

²) Port size acc. to DIN ISO 228 (BSP-P).

Product key

Series	Size	/Press. rating	Design	Generation	-Port type	Powersupply	Control
H	15 up to 70	/100	D	2	-G	230	MT

HDK-MT 15/100 up to 70/100 in standard design with connection BSP-P, Multitronic dew-point dependent control with 230 V/50-60 Hz.

^{*}) Alternative designs, e.g. 115V/50-60Hz power supply or mounted accessories ex works on request as well as further approvals, breathing air design acc. to EN 12021, higher pressure ratings, PLC control, full stainless steel design a.o.

Correction factor CFP in accordance to actual minimum operating pressure in bar_e

Inlet temperature in °C	50	75	100
Correction factor CFP	2,0	1,33	1

Correction factor CFT in accordance to actual compressed air inlet temperature in °C

Inlet temperature in °C	30	35	40	45	50	55
Correction factor CFT	1	1	1,29	1,67	2,08	2,68

Example of a maximum flow rate of 350 m³/h at minimum operating pressure of 75 bar_e and 40 °C compressed air inlet temperature: 350 m³/h x 1.33 x 1.29 = 600.5 m³/h – select model HDK-MT 70/100 (see table *order and performance information*).

Range of application

Flow medium	Compressed air and gaseous Nitrogen
Operating press., min./max.	50 up to 100 bar _e
Medium inlet temperature	1 up to 55 °C
Ambient temperature	1 up to 50 °C

Electrical connection

Power supply	230 V, 50-60 Hz (standard); 115 V, 50-60 Hz (on request)
Ingress protection	IP65

Approvals for pressure equipment

EU	Pressure equipment directive 97/23/EC for fluid group 2
GUS	TR (former GOST-R)

Quality assurance and guarantee

Development/manufacture	DIN EN ISO 9001, DIN EN ISO 14001
Helium leakage test	< 10 ⁻⁶ mbar/Ls leakage rate

Product Specification

High-pressure dryer series HDK-MT up to 100 bar

Dimension (mm) and weight (kg)

Model	A	B	C	Weight
HDK-MT 15/100	700	1050	370	160
HDK-MT 20/100	700	1250	370	180
HDK-MT 25/100	700	1450	370	200
HDK-MT 30/100	700	1650	370	220
HDK-MT 40/100	770	1650	370	240
HDK-MT 50/100	770	1850	450	260
HDK-MT 70/100	770	2075	450	280

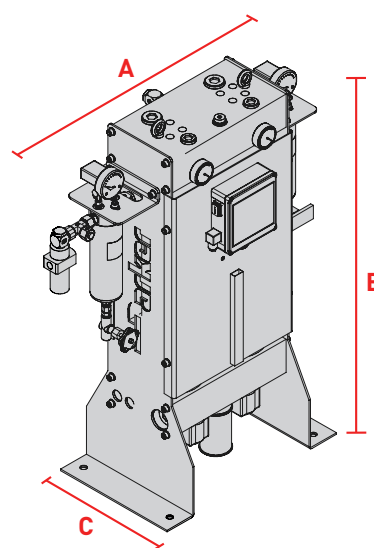

Materials

Valve blocks	Aluminium, hard coated	
Seamless vessel pipes	Stainless steel	
Fittings	Stainless steel	
Valves	Stainless steel/POM/PEEK	
Frame	Carbon steel, KTL primed and powder coated	
Seals	NBR/FPM	
Adsorbents	3-layer filling of ceramic/silica gel/molecular sieve beads	
Filter	GH7/100 for HDK-MT 15/100 up to 30/100	GH9/100 for HDK-MT 40/100 up to 70/100
Housing	Aluminium anodised, outside powder coated	Carbon steel, inside primed, outside powder coated
Tie rod	Stainless steel	
Filter element	Borosilicate nano fibres, stainless steel expanded metals, Polyamide end caps, Polyurethane adhesive	
Seals	NBR/FPM	
Needle valve (drain)	Stainless steel	

Accessories, lose or mounted ex works

Start-up device		
Order no.	Description	Suitable for model
VASVPB/100/15	Pressure maintaining valve G1/2 PN100 incl. adjustable opening pressure incl. fitting and T-piece for regeneration gas back flow	HDK-MT 15/100 up to HDK-MT 30/100
VASVPB/415/20	Pressure maintaining valve G3/4 PN415 incl. adjustable opening pressure incl. fitting and T-piece for regeneration gas back flow	HDK-MT 40/100 up to HDK-MT 70/100
Time controlled drains for prefilter, various power supplies		
Order no.	Description	Suitable for model
TRAP2/100-G230/P	Time controlled solenoid valve G1/4i, PN100, 2-55 °C, 230 VAC, IP65	all
TRAP2/100-G115/P	Time controlled solenoid valve G1/4i, PN100, 2-55 °C, 115 VAC, IP65	all
TRAP2/100-G24D/P	Time controlled solenoid valve G1/4i, PN100, 2-55 °C, 24 VDC, IP65	all
Differential pressure gauges for pre- and afterfilter		
Order no.	Description	Suitable for model
HZD80/420RG	calibrated analogue differential pressure gauge PN420	all
HZDE80/420RG	calibrated analogue differential pressure gauge PN420 incl. reed contact (IP54)	all
Signal splitter		
Description	Suitable for model	Suitable for model
VASMBS420	analogue output contact 4-20 mA for dew-point signal	all

Product Specification

High-pressure dryer series HDK-MT up to 100 bar

Service kits: Preventative maintenance sets

For model	Order no.	Service interval	Scope of supply
HDK-MT 15/100 - HDK-MT 30/100	SKH15-H30/D2/12	12 month	Reset module, pre-/afterfilter element, four o-rings filter housing, four valves V1-V4
HDK-MT 40/100 up to HDK-MT 70/100	SKH40-H70/D2/12		
HDK-MT 15/100 - HDK-MT 30/100	SKH15-H30/D2/24	24 month	Reset module, pre-/afterfilter element, four o-rings filter housing, four valves V1-V4 as well as four o-rings vessel nozzles, four o-rings vessel piston, two dust sieves, five pilot valves Y1-Y5, two check valves RV5-RV6
HDK-MT 40/100 up to HDK-MT 70/100	SKH40-H70/D2/24		

Desmix: Preventative and tailored adsorbent packages per model

For model	Order no.	Service interval	Scope of supply
HDK-MT 15/100	HDK-MT15/100DESMIX	24 month	ceramic/silica gel/molecular sieve beads
HDK-MT 20/100	HDK-MT20/100DESMIX		
HDK-MT 25/100	HDK-MT25/100DESMIX		
HDK-MT 30/100	HDK-MT30/100DESMIX		
HDK-MT 40/100	HDK-MT40/100DESMIX		
HDK-MT 50/100	HDK-MT50/100DESMIX		
HDK-MT 70/100	HDK-MT70/100DESMIX		

Repair kits: Further wear part sets as required

For model	Order no.	Service interval	Scope of supply
all	RKH15-H70/RV1-RV4	as required	Four check valves RV1-RV4
	RKESC-HDK-230-NH		Five solenoid coils 230V/50-60Hz
	RKESC-HDK-115-NH		Five solenoid coils 115V/50-60Hz
	RKH15-H70/PWS		Two vessel nozzles incl. o-rings

Further spare parts as required

For model	Order no.	Service interval	Scope of supply
all	SDD-15/600/AL	as required	Silencer
	ZHM100/450		Dew-point sensor
	ET-HDK-MT/2/VN		Needle valve VN (for regeneration gas)
	ET-HDK-MT/2/MV-BLOCK		Solenoid valve block without coils
	ET-HDK-MT/2/RV-BLOCK		Check valve block without needle valve VN, without gauges
	ET-MANO.063MR0813		Gauge incl. seal

EMEA Product Information Centre

Free phone: 00 800 27 27 5374

(from AT, BE, CH, CZ, DE, DK, EE, ES, FI, FR, IE, IL, IS, IT, LU, MT, NL, NO, PL, PT, RU, SE, SK, UK, ZA)

US Product Information Centre

Toll-free number: 1-800-27 27 537

www.parker.com/hzd